

Air Management System

Sustainability – Condition Based Maintenance – Digitalisation

New



Standby regulator

Switch pressure between operation and standby

Air management hub

Flow rate, pressure, and temperature sensing
Communication function

Residual pressure relief valve

Secondary air supply or exhaust (shut-off) switching

Wireless adapter

(Accessories p.46)

Air consumption:
Max. 62 %*1 reduction

p. 1

*1 In SMC conditions:

Maximum reduction ratio within product specifications
(at 0.7 MPa operating pressure and 0.2 MPa low pressure)

Monitors the machine standby conditions (when production stops) and automatically decreases the pressure.
Reduces unnecessary air consumption

Compatible with OPC UA p. 2

Direct connection enables data communications.

Compatible with PROFINET and EtherNet/IP

Compatible with SMC wireless systems p. 3

- Communication cables not required
- High security using unique encryption
- Communication distance: Max. 100 m

AMS20/30/40/60 Series



CAT.EUS100-155A-UK

Why not reduce the wasted air generated by your factory equipment?



Blow and purge in equipment standby

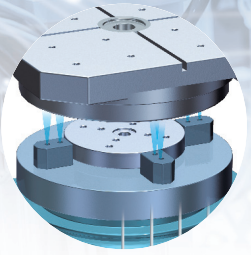

Leakage from piping connections due to poor piping installation

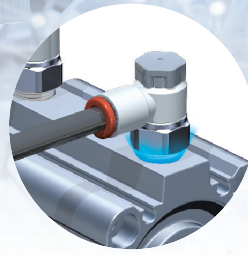

Leakage from cylinder due to worn seals

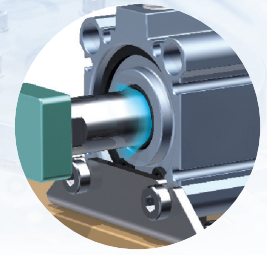

Reduce air consumption by lower pressure during equipment standby **Standby mode**

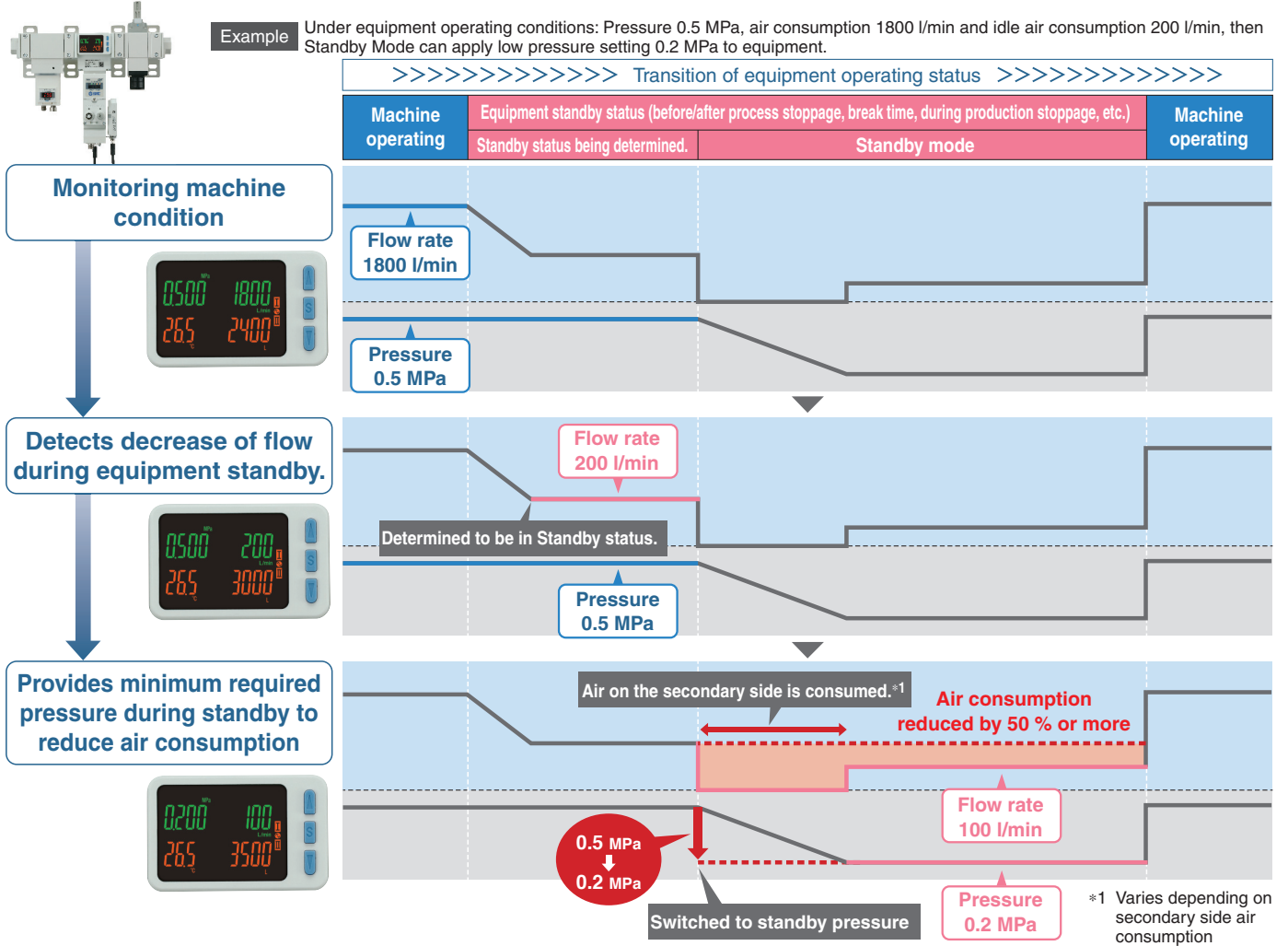

Reduce air consumption by shutting off valves depending on equipment shutdown conditions **Isolation mode**

Residual pressure exhaust valve allows further reduction of air consumption by shutting off the air supply.
Automatic isolation mode is also provided that can be turned off after a set time from standby mode.

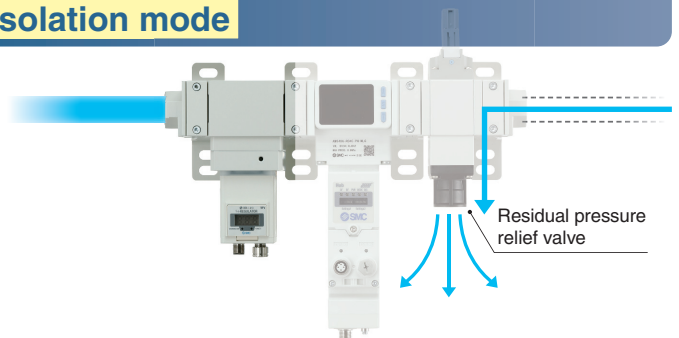

Visualisation of production equipment status

Flow, pressure, temperature, and other sensor information can be communicated to the host system via Industrial Ethernet or the OPC UA data communication protocol.



Equipment status can be monitored from another location or from outside the office.

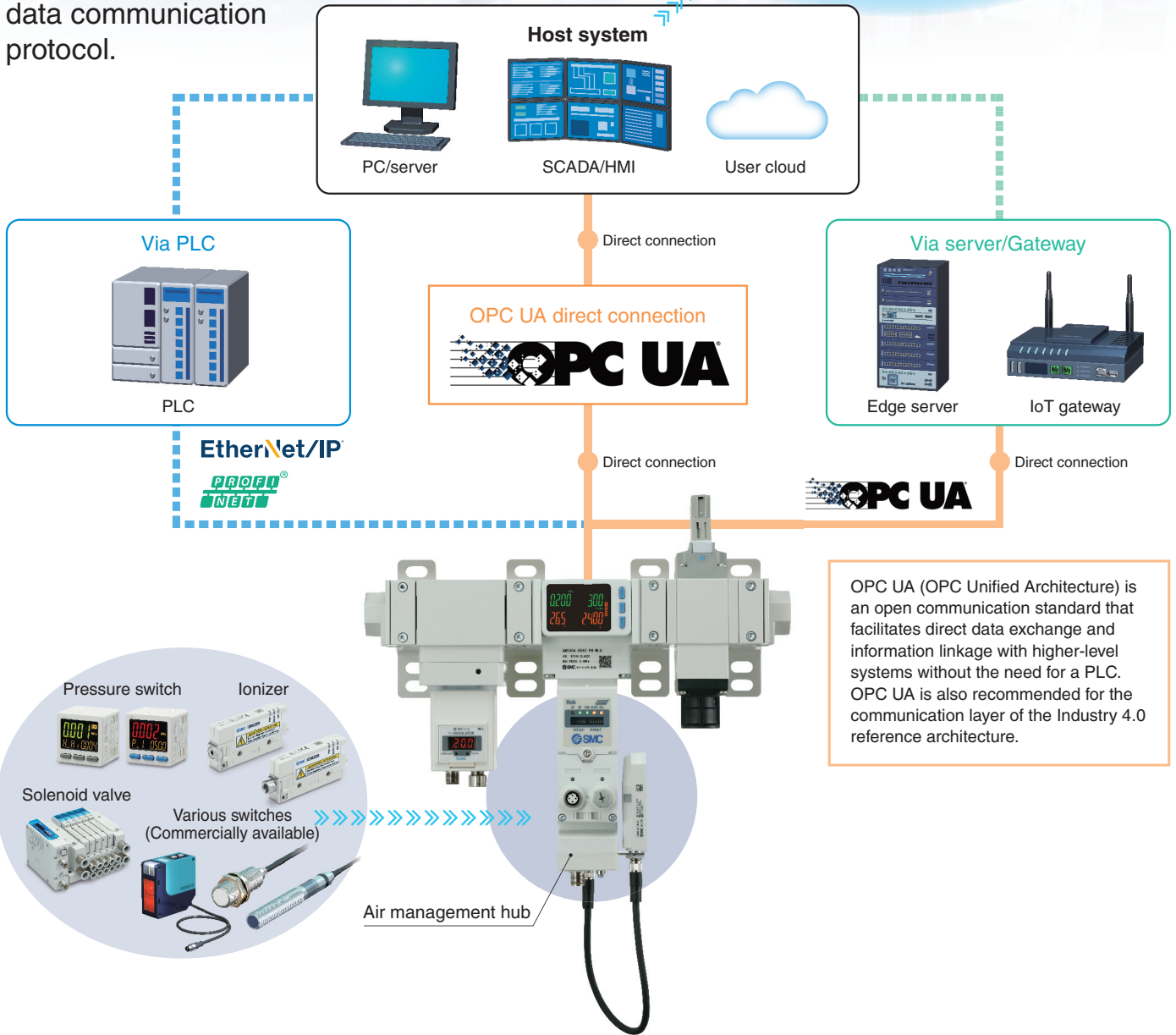

OPC UA (OPC Unified Architecture) is an open communication standard that facilitates direct data exchange and information linkage with higher-level systems without the need for a PLC. OPC UA is also recommended for the communication layer of the Industry 4.0 reference architecture.

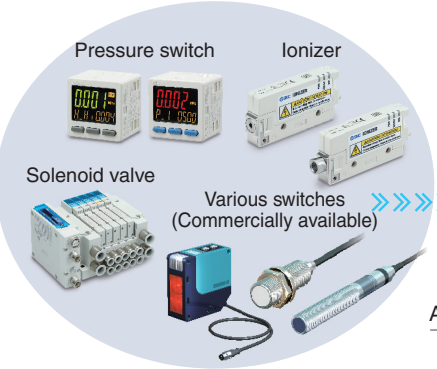

IO-Link compatible

IO-Link port on the back of the air management hub

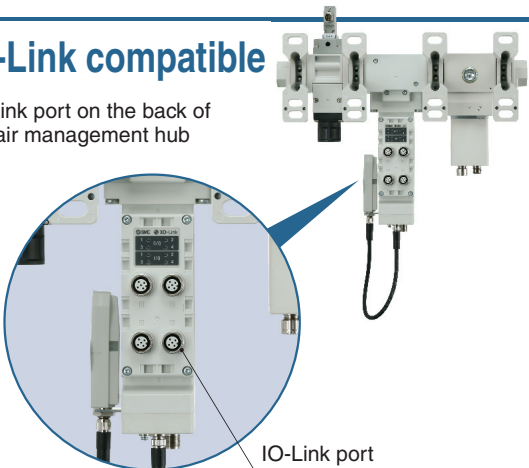

Examples of IoT applications with Air Management System

Remote monitoring and control is possible.

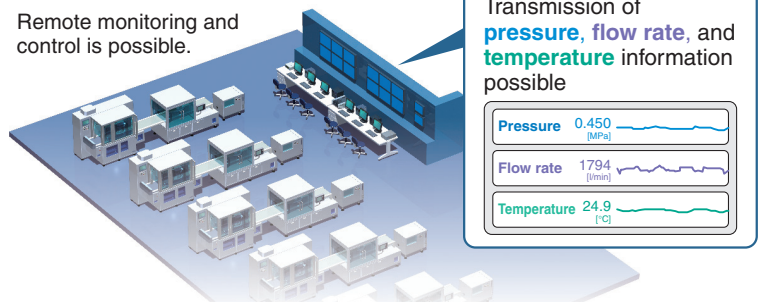

Compatible with SMC wireless systems*1

*1 When connecting a wireless adapter (sold separately)

- No communication cable required between the base and remote
Reduced wiring work, space, and cost
Minimised disconnection risk
- Connectivity to up to 10 remotes (AMS20/30/40/60 or compact wireless module)

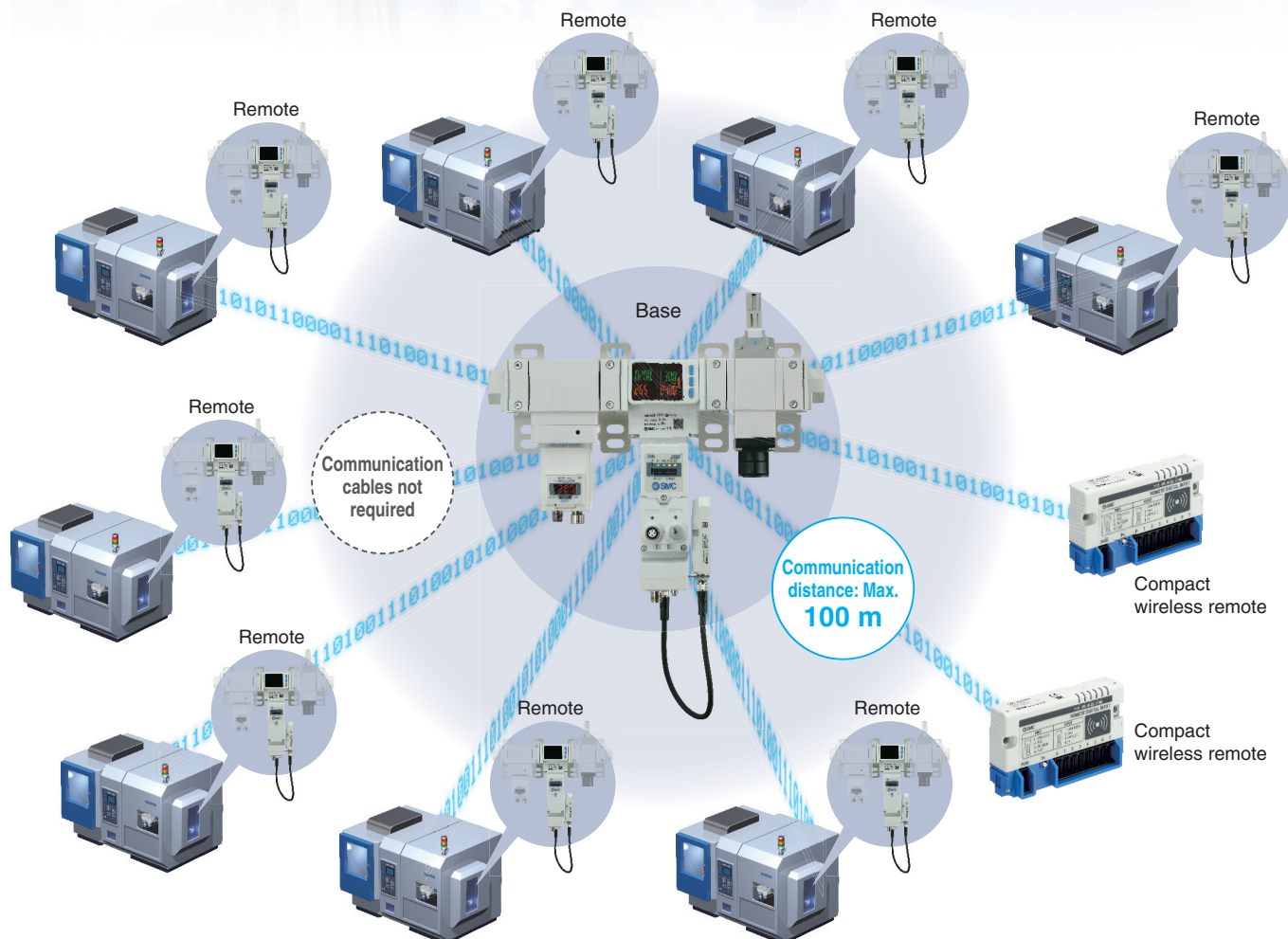

High security using encryption

Unauthorized access is prevented by using data encryption.

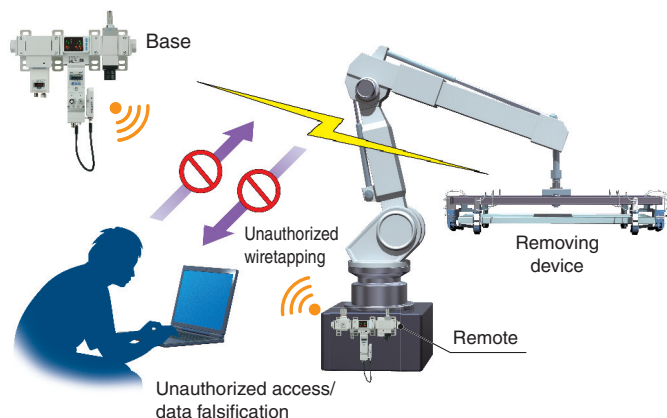

Retrofitted to existing equipment

Can be introduced by OPC UA or the wireless system without connecting to a PLC or changing the program. Modular type F.R.L combination can be connected.

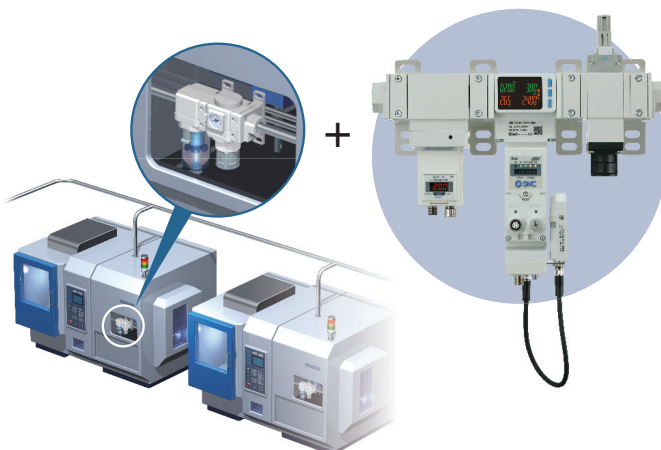

System Configuration

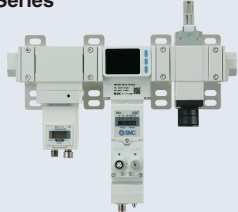
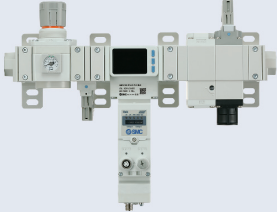
Series	Size	Port size						Flow capacity [l/min]								Communication protocol	Output data
		1/8	1/4	3/8	1/2	3/4	1	5	10	20	40	500	1000	2000	4000		
Electro-Pneumatic Regulator Type AMS20A/30A/40A/60A Series 	20	●	●					[Flow Capacity Range]								PROFINET EtherNet/IP™ OPC UA	· Instantaneous flow · Accumulated flow · Pressure · Fluid temperature · Various sensor information transmitted via IO-Link · Diagnosis
	30		●	●			[Flow Capacity Range]										
	40				●	●		[Flow Capacity Range]									
	60						●	●	[Flow Capacity Range]								
Regulator Type AMS20B/30B/40B/60B Series 	20	●	●				[Flow Capacity Range]										
	30		●	●			[Flow Capacity Range]										
	40			●	●		[Flow Capacity Range]										
	60					●	●	[Flow Capacity Range]									

Components

Air Management Hub

When connected to a wireless adapter, it has the ability to communicate with upper level system and wireless communication. Standby regulator and residual pressure exhaust valve are connected to control the air management system.

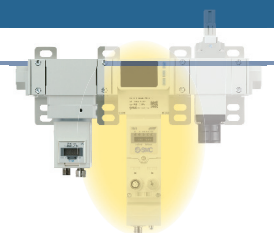

Upper Communication Type

Front



Back

The back shape and dimensions are the same for both upper level communication and stand-alone operation types.

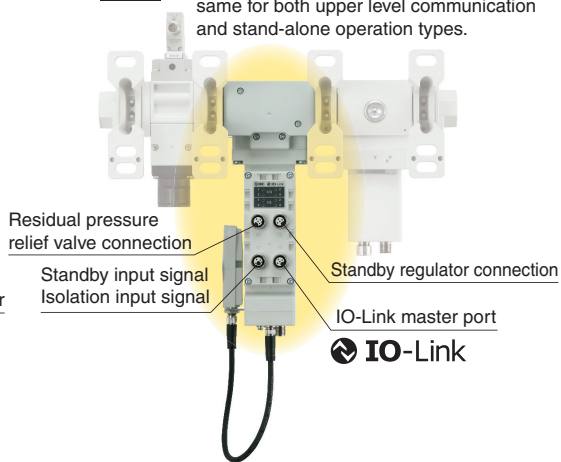

Stand-alone Operation Type

Front



- Industrial Ethernet



EtherNet/IP

- Data communication protocol



- IO-Link master function



- Wireless base function (When wireless adapter is connected)

- Wireless remote function (When wireless adapter is connected)

Trademark

EtherNet/IP® is a registered trademark of ODVA, Inc.



Components

Standby Regulator

Based on the signal from the air management hub, the operating mode shifts to standby mode and regulates the pressure to the standby pressure. The non-relief type allows efficient use of air by not exhausting secondary-side air during the standby mode transition.



Electro-Pneumatic Regulator Type (ITV series/For the AMS20A/30A/40A/60A series)



- Remote pressure setting and switching during equipment startup/shutdown
- Select from normally closed or normally open.
- With backflow function
- With pressure ramp up duration setting function

Regulator Type (ARS series/For the AMS20B/30B/40B/60B series)



- Manual pressure setting and switching during equipment shutdown (Equipment operating pressure is not changed.)
- Normally open specification
- With backflow function

Residual Pressure Relief Valve

Based on the signal from the air management hub, the operating mode shifts to isolation mode.

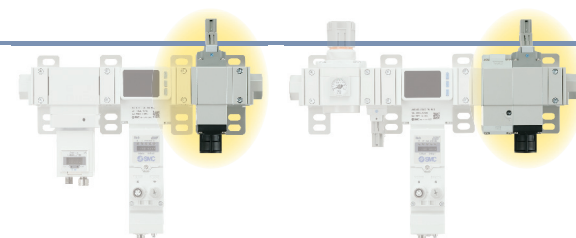

Without Soft Start-up Function (For the AMS20A/30A/40A/60A series)



- Block the air supply to the secondary side.
- Select from normally closed or normally open.

With Soft Start-up Function (For the AMS20B/30B/40B/60B series)

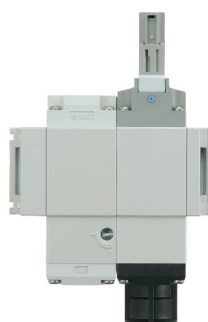

- Block the air supply to the secondary side.
- Slow air ramp-up when equipment is restarted
- Select from normally closed or normally open.

CONTENTS

Air Management System *AMS20/30/40/60 Series*

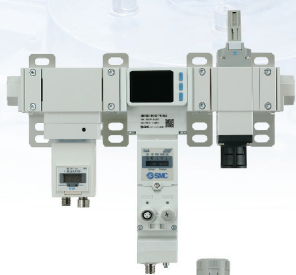

Air Management System Electro-Pneumatic Regulator Type AMS20A/30A/40A/60A Series

How to Order p. 7
Standard Specifications p. 8



Air Management System Regulator Type AMS20B/30B/40B/60B Series

How to Order p. 13
Standard Specifications p. 14

Flow Rate Characteristics p. 9, 15
Dimensions
Electro-Pneumatic Regulator Type p. 17
Regulator Type p. 19



Air Management Hub EXA1 Series

How to Order p. 21
Specifications p. 21
Dimensions p. 22



Standby Electro-Pneumatic Regulator ITV2050 to 3050-X399

How to Order p. 24
Specifications p. 24
Dimensions p. 25



Standby Regulator AR20S to 50S Series

How to Order p. 27
Specifications p. 27
Dimensions p. 28

Residual Pressure Relief 3-Port Solenoid Valve VP346E/546E/746E/946E-X660/X661

How to Order p. 29
Specifications p. 29
Dimensions p. 30

Accessories p. 46

- ① Wireless Adapter p. 47
- ② Seal Cap (10 pcs.) p. 47
- ③ Power Supply Cable
[M8 connector, For EXW1-A11N-X1, With connectors on both
sides (socket/plug)] p. 47
- ④ Power Supply Cable (M12 connector, For EXA1) p. 48
- ⑤ Connection Cable for Standby Regulator/Residual Pressure Relief Valve
[With M12 angle connectors on both sides (male/female)] p. 48

- ⑥ Piping Adapter p. 49
- ⑦ Spacer with Bracket p. 49
- ⑧ Silencer p. 50
- ⑨ Marker (1 sheet, 88 pcs.) p. 51
- ⑩ Communication Cable p. 51
- ⑪ Cable with Connector for IO-Link Unit p. 52
- ⑫ I/O Cable with Connector, I/O Connector p. 52
- ⑬ IO-Link Device Tool License Key p. 52

Specific Product Precautions p. 53

Air Management System Electro-Pneumatic Regulator Type



RoHS

AMS20A/30A/40A/60A Series

Symbol

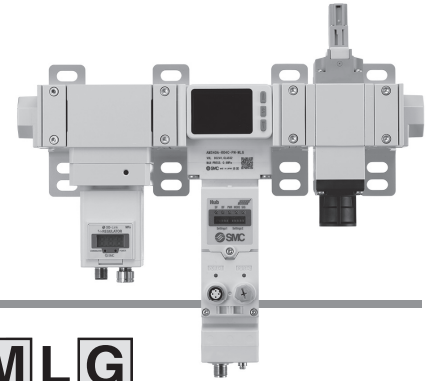
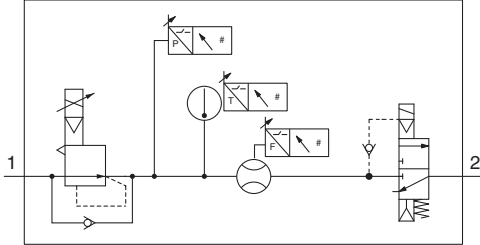

How to Order

AMS **40** A - **F** **04** **C** - **PN** - **M** **L** **G**

①
②
③
④
⑤
⑥
⑦

	Symbol	Description	①			
			Body size			
			20	30	40	60
② Pipe thread type	R	Rc	●	●	●	●
	N	NPT	●	●	●	●
	F	G	●	●	●	●
	H	Without attachments	●	●	●	●
+						
③ Port size	01	1/8	●	—	—	—
	02	1/4	●	●	—	—
	03	3/8	—	●	●	—
	04	1/2	—	—	●	—
	06	3/4	—	—	—	●
	10	1	—	—	—	●
	00	Without attachments	●	●	●	●
+						
④ N.O./N.C.	C	N.C. (Normally closed)	●	●	●	●
	D	N.O. (Normally open)	●	●	●	●
+						
⑤ Protocol	SA	Standalone (When wireless adapter is connected*2: Wireless remote)	●	●	●	●
	PN	PROFINET, OPC UA (When wireless adapter is connected*2: Wireless base)	●	●	●	●
	EN	EtherNet/IP™, OPC UA (When wireless adapter is connected*2: Wireless base)	●	●	●	●
+						
⑥ Unit	K	EXA1/ITV: Units selection function	●	●	●	●
	M*1	EXA1/ITV: SI units only	●	●	●	●
+						
⑦ Manual override	G	Non-locking push type	●	●	●	●
	E	Push-turn locking type (Manual)	●	●	●	●

*1 Fixed units Instantaneous flow: l/min
Accumulated flow : L
Pressure : kPa, MPa
Temperature : °C

*2 The wireless adapter is sold separately. (Refer to page 47.)

Standard Specifications: Electro-Pneumatic Regulator Type

Model		AMS20A	AMS30A	AMS40A	AMS60A
Component	Standby electro-pneumatic regulator	ITV2050-20	ITV2050-30	ITV3050-40	ITV3050-60
	Air management hub	EXA1-20	EXA1-30	EXA1-40	EXA1-60
	Residual pressure relief valve	VP346E	VP546E	VP746E	VP946E
Port size		1/8, 1/4	1/4, 3/8	3/8, 1/2	3/4, 1
Fluid		Air			
Rated flow range		5 to 500 l/min	10 to 1000 l/min	20 to 2000 l/min	40 to 4000 l/min
Ambient and fluid temperatures		0 to 50 °C			
Proof pressure		1.0 MPa			
Max. operating pressure		0.8 MPa			
Supply pressure range		0.3 to 0.8 MPa			
Set pressure range		0.2 to 0.7 MPa			
Standby pressure range		0.2 to 0.4 MPa			
Power supply voltage		24 VDC ±10 %			
Current consumption		500 mA or less			
Input/Output		DI x 2 DI, DO IO-Link, DI			
Enclosure		IP65 (Electrical equipment part only)			
Weight		2200 g	2500 g	3800 g	5800 g

AMS20A/30A/40A/60A Series

Flow Rate Characteristics (Representative values): AMS20A/Electro-Pneumatic Regulator Type

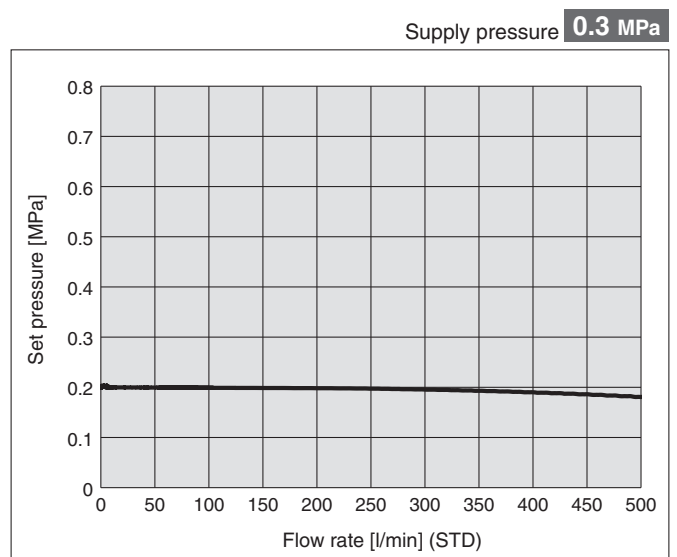
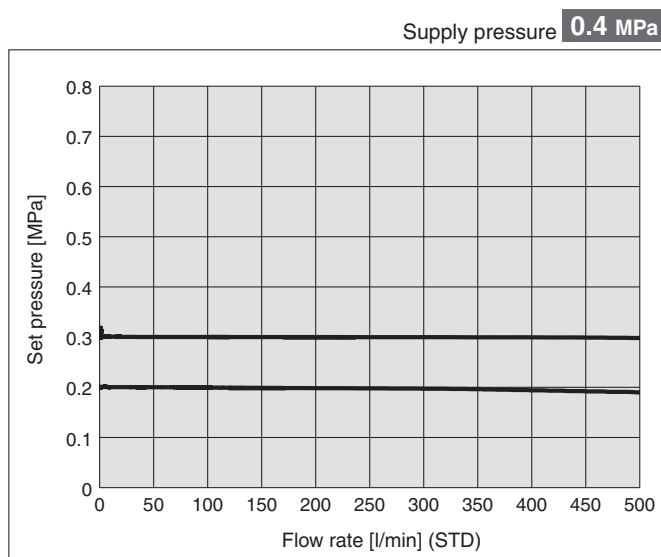
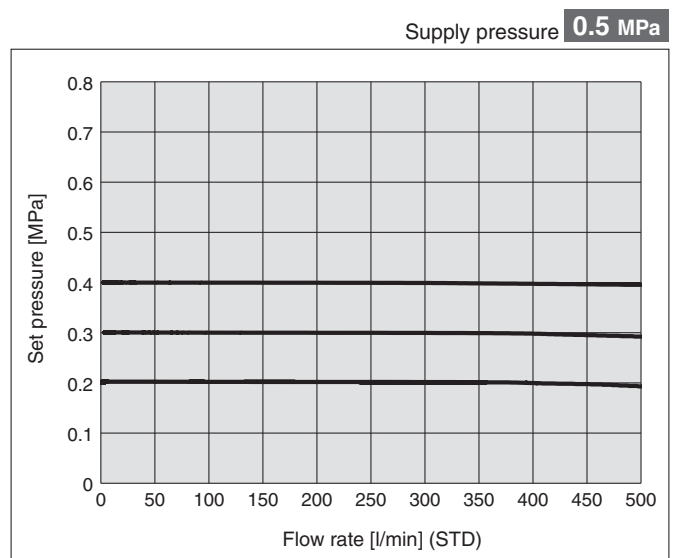
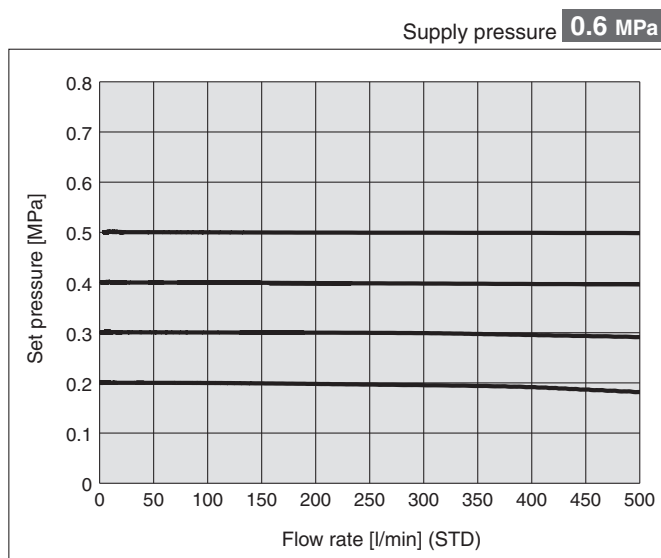
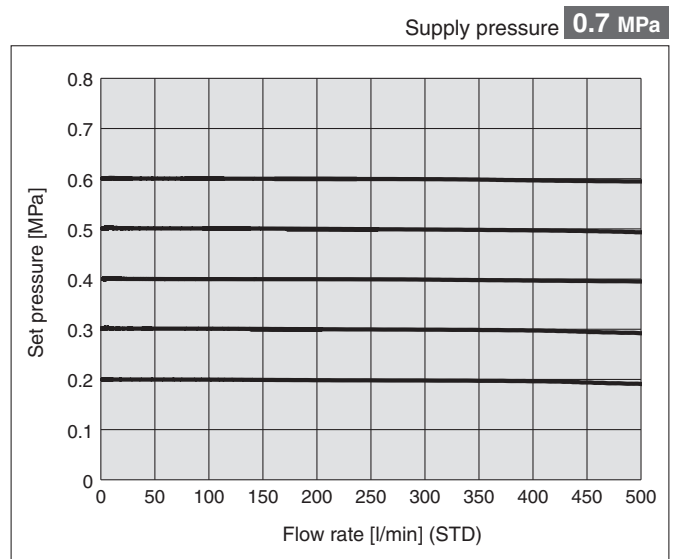
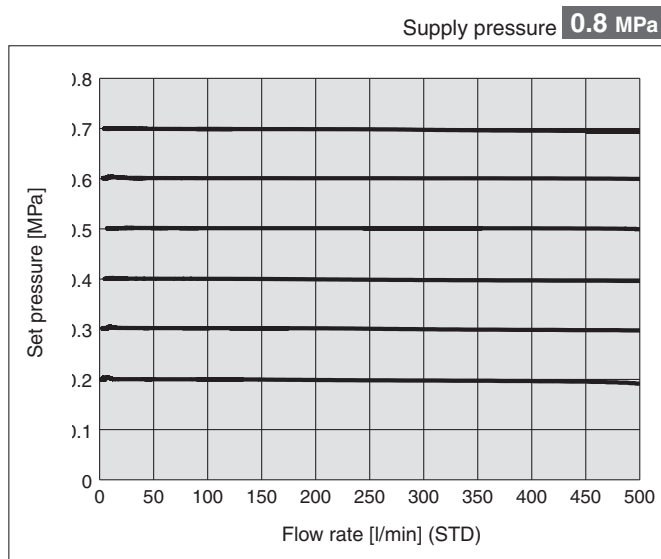

Flow Rate Characteristics (Representative values): **AMS30A/Electro-Pneumatic Regulator Type**

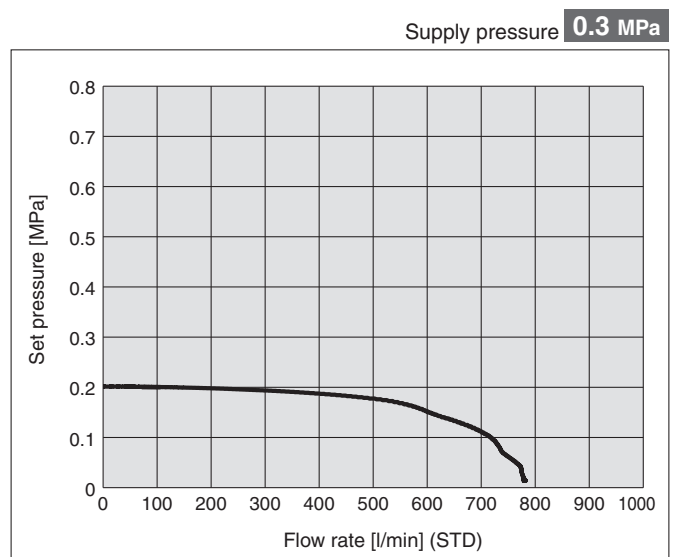
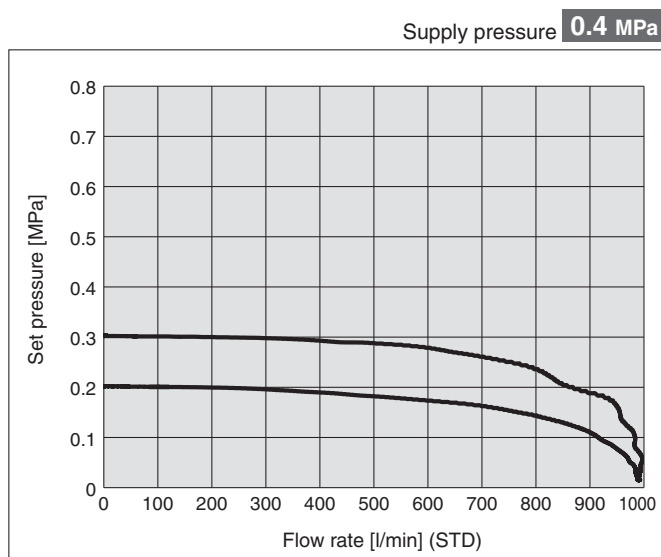
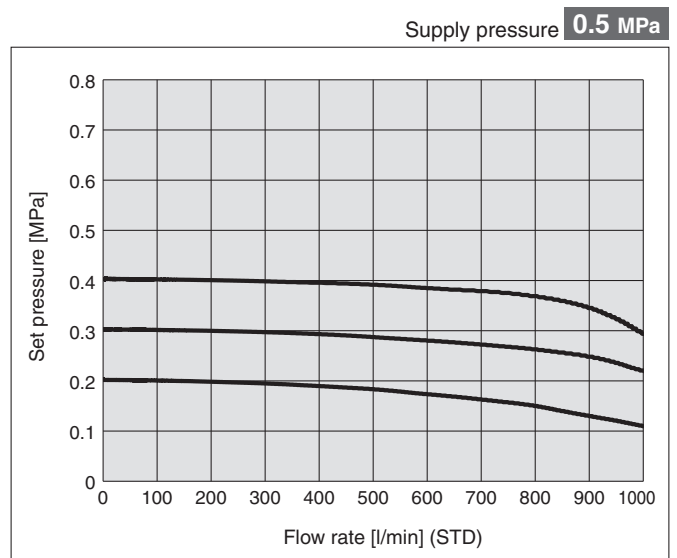
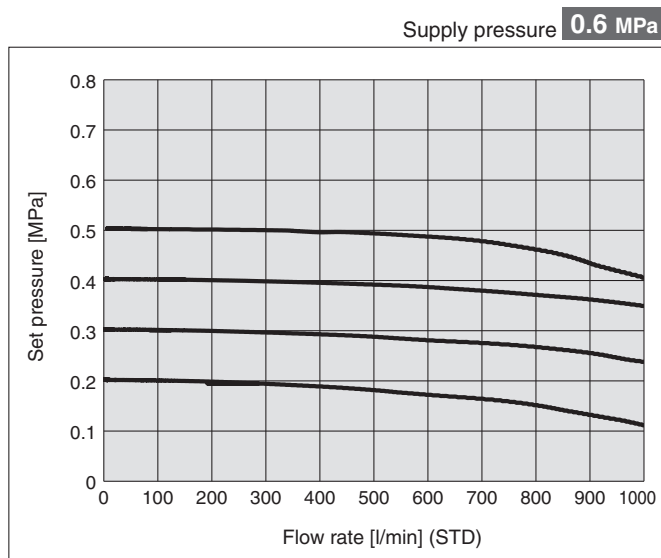
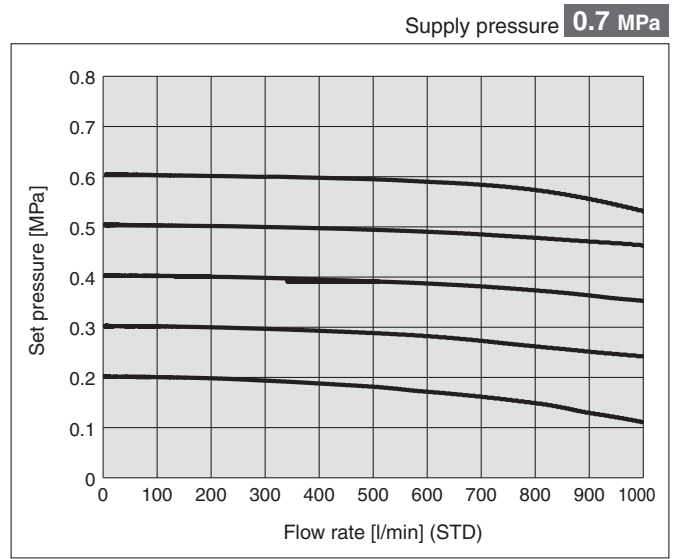
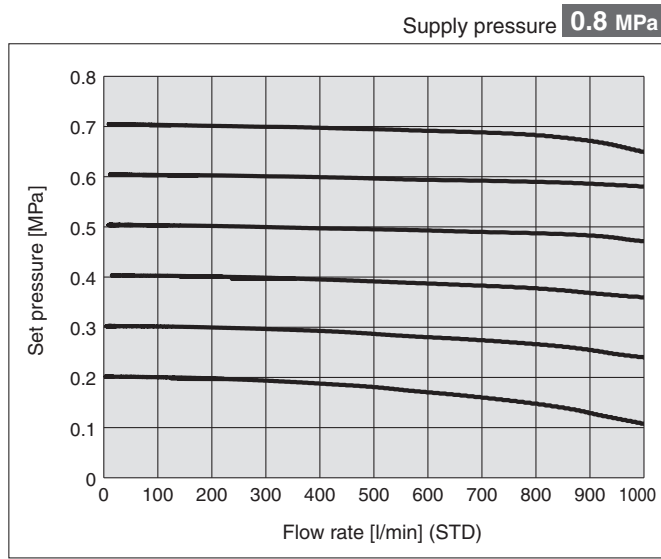

AMS20A/30A/40A/60A Series

Flow Rate Characteristics (Representative values): AMS40A/Electro-Pneumatic Regulator Type

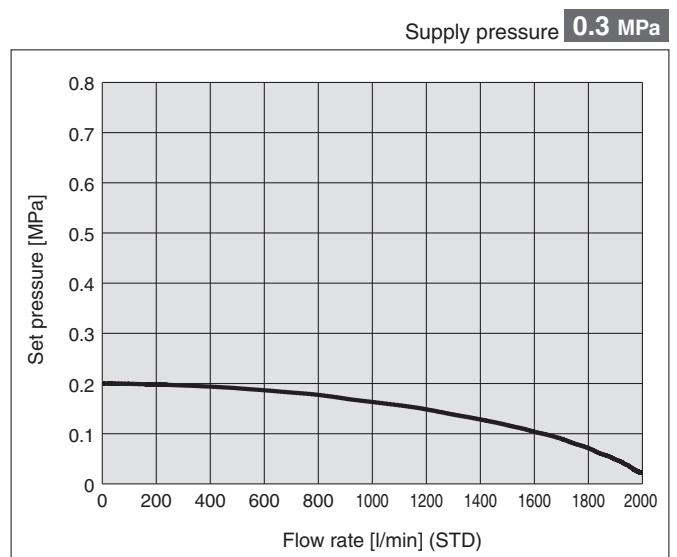
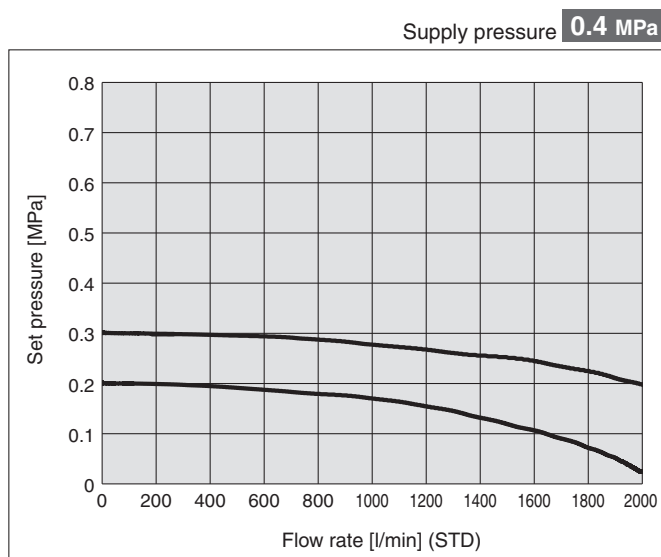
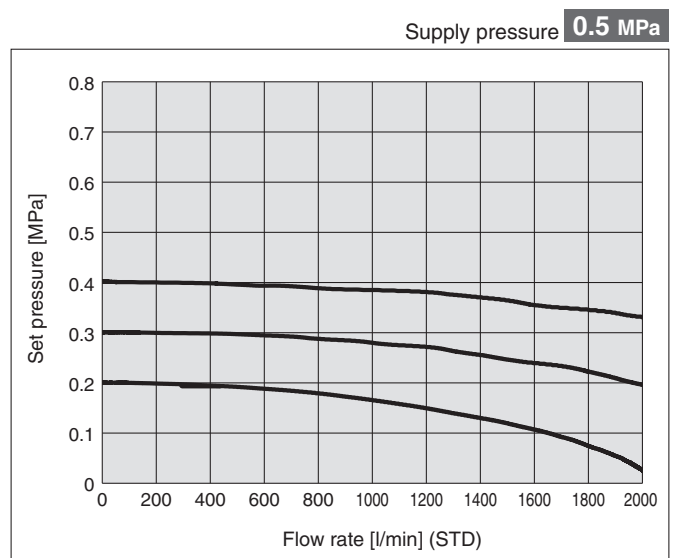
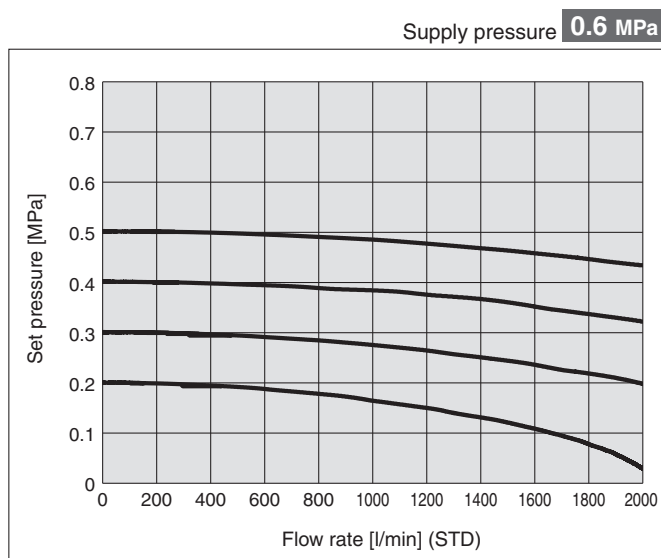
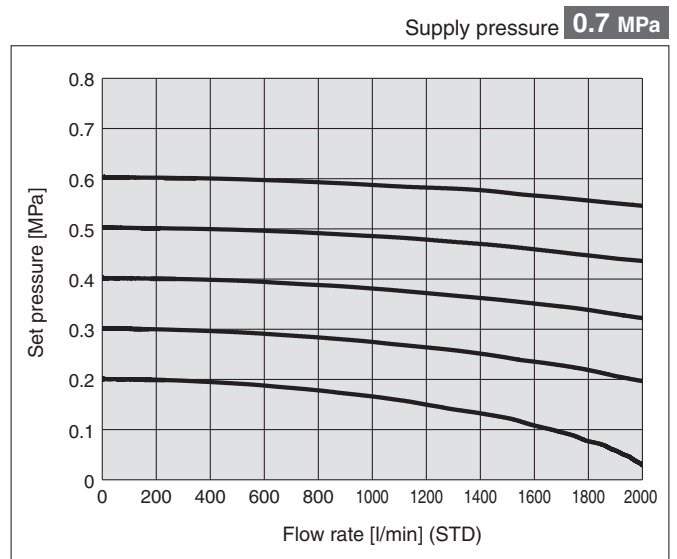
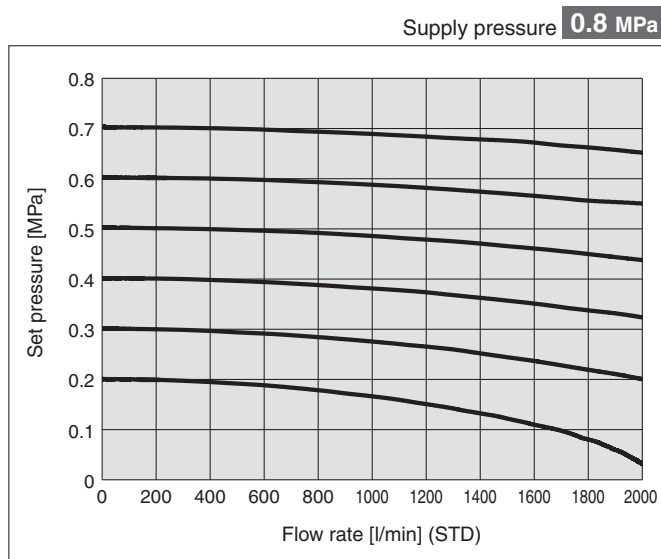

Flow Rate Characteristics (Representative values): **AMS60A/Electro-Pneumatic Regulator Type**

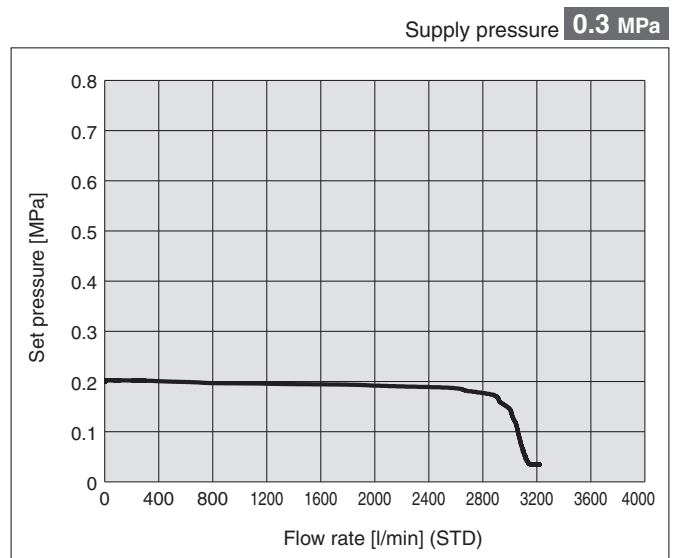
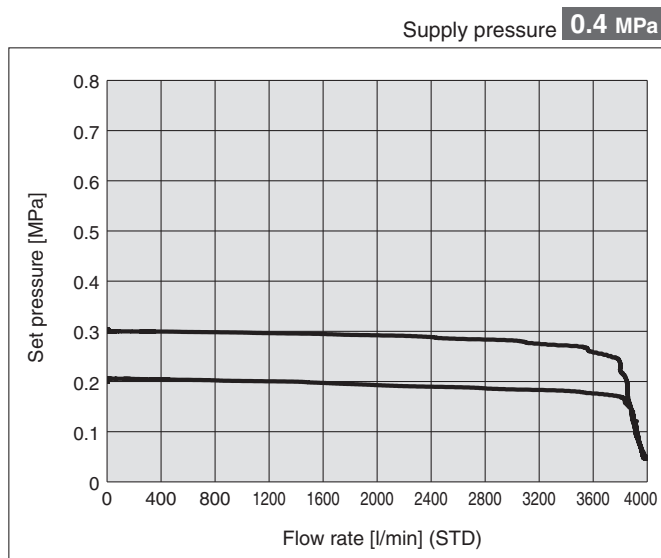
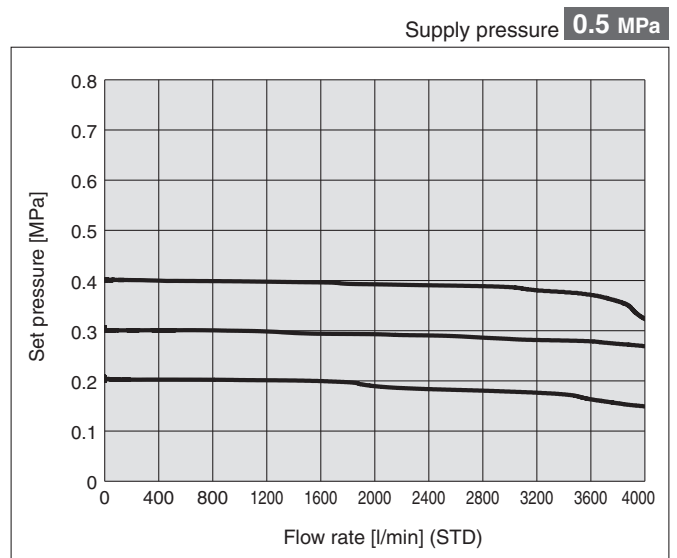
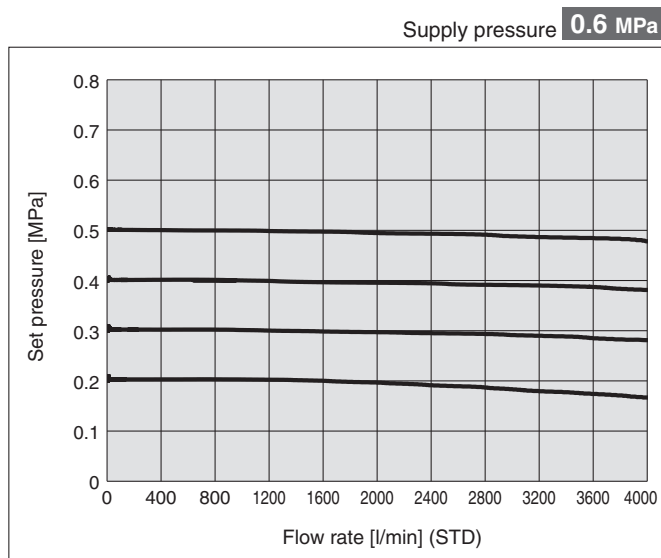
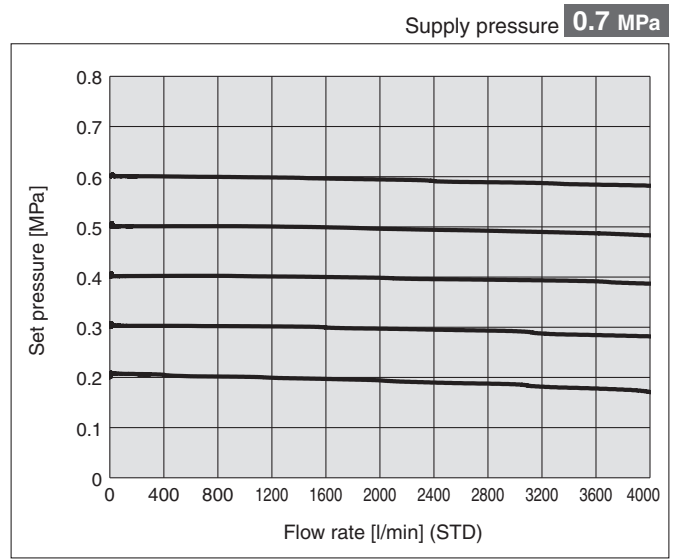
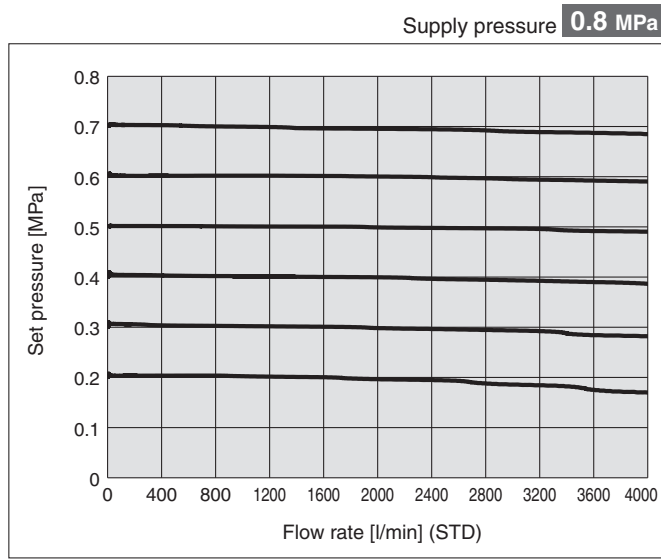

Air Management System Regulator Type



RoHS

AMS20B/30B/40B/60B Series

Symbol

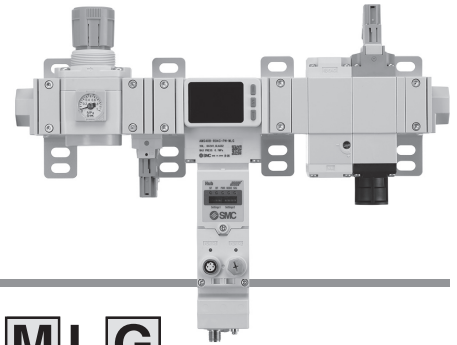
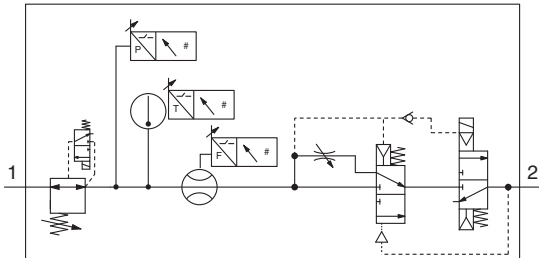

How to Order

AMS **40** B - **F** **04** **C** - **PN** - **M** **L** **G**

①
②
③
④
⑤
⑥
⑦

	Symbol	Description	① Body size			
			20	30	40	60
② Pipe thread type*1	R	Rc	●	●	●	●
	N	NPT	●	●	●	●
	F	G	●	●	●	●
+						
③ Port size	01	1/8	●	—	—	—
	02	1/4	●	●	—	—
	03	3/8	—	●	●	—
	04	1/2	—	—	●	—
	06	3/4	—	—	—	●
	10	1	—	—	—	●
	00	Without attachments	●	●	●	●
+						
④ N.O./N.C.	C	N.C. (Normally closed)	●	●	●	●
	D	N.O. (Normally open)	●	●	●	●
+						
⑤ Protocol	SA	Standalone (When wireless adapter is connected*3: Wireless remote)	●	●	●	●
	PN	PROFINET, OPC UA (When wireless adapter is connected*3: Wireless base)	●	●	●	●
	EN	EtherNet/IP™, OPC UA (When wireless adapter is connected*3: Wireless base)	●	●	●	●
+						
⑥ Unit	K	Pressure gauge: MPa/psi dual scale, EXA1: Units selection function	●	●	●	●
	M	Pressure gauge in SI units: MPa, EXA1: SI units only*2	●	●	●	●
+						
⑦ Manual override	G	Non-locking push type	●	●	●	●
	E	Push-turn locking type (Manual)	●	●	●	●

*1 For port size "00", specify thread type of the standby regulator (ARS).

*2 Fixed units
 Instantaneous flow: l/min
 Accumulated flow : L
 Pressure : kPa, MPa
 Temperature : °C

*3 The wireless adapter is sold separately. (Refer to page 47.)

Standard Specifications: Regulator Type

Model		AMS20B	AMS30B	AMS40B	AMS60B
Component	Standby regulator	AR20S	AR30S	AR40S	AR50S
	Air management hub	EXA1-20	EXA1-30	EXA1-40	EXA1-60
	Residual pressure relief valve	VP346E	VP546E	VP746E	VP946E
Port size		1/8, 1/4	1/4, 3/8	3/8, 1/2	3/4, 1
Fluid		Air			
Rated flow range		5 to 500 l/min	10 to 1000 l/min	20 to 2000 l/min	40 to 4000 l/min
Ambient and fluid temperatures		0 to 50 °C			
Proof pressure		1.0 MPa			
Max. operating pressure		0.7 MPa			
Supply pressure range		0.3 to 0.7 MPa			
Standby pressure range		0.2 to 0.4 MPa			
Power supply voltage		24 VDC ±10 %			
Current consumption		400 mA or less			
Input/Output		DI x 2 DI, DO IO-Link, DI			
Enclosure		IP65 (Electrical equipment part only)			
Weight		1800 g	2500 g	3800 g	6500 g

AMS20B/30B/40B/60B Series

Flow Rate Characteristics (Representative values): AMS20B/30B/40B/60B/Regulator Type

Conditions/Supply pressure: 0.3 to 0.7 MPa, Standby pressure: 0.2 MPa Operation mode

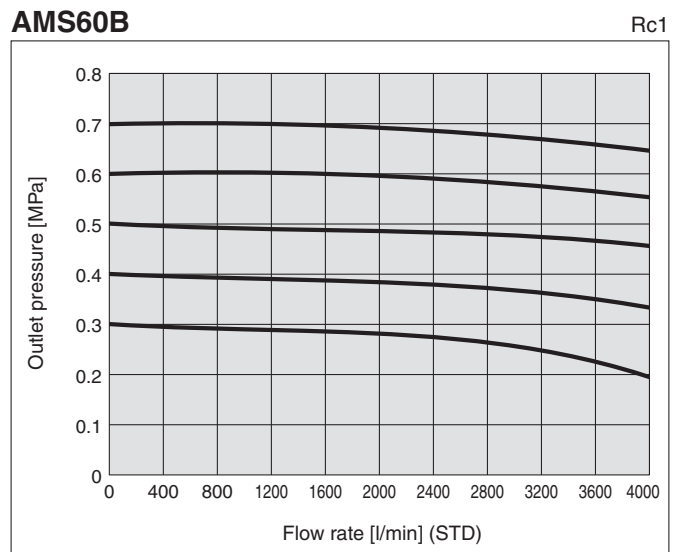
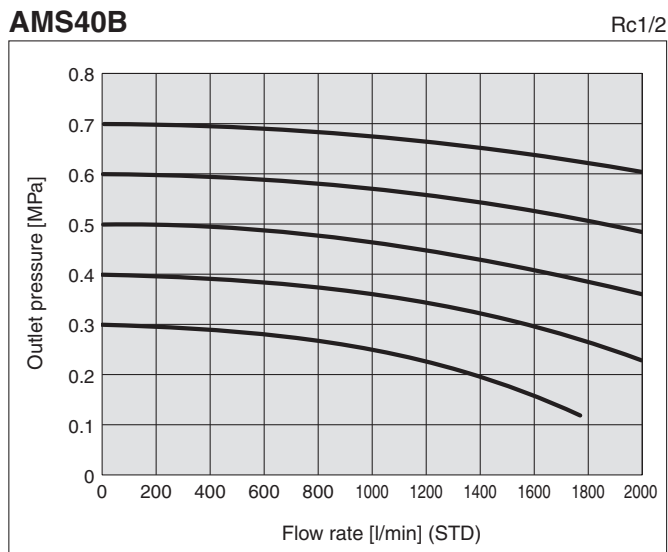
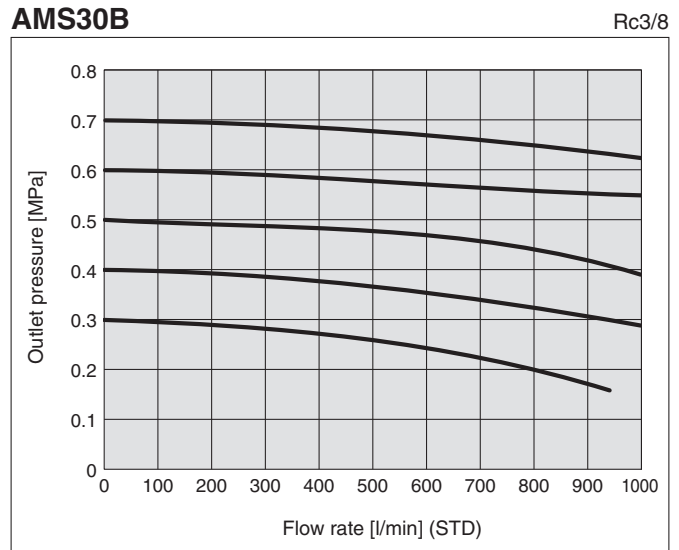
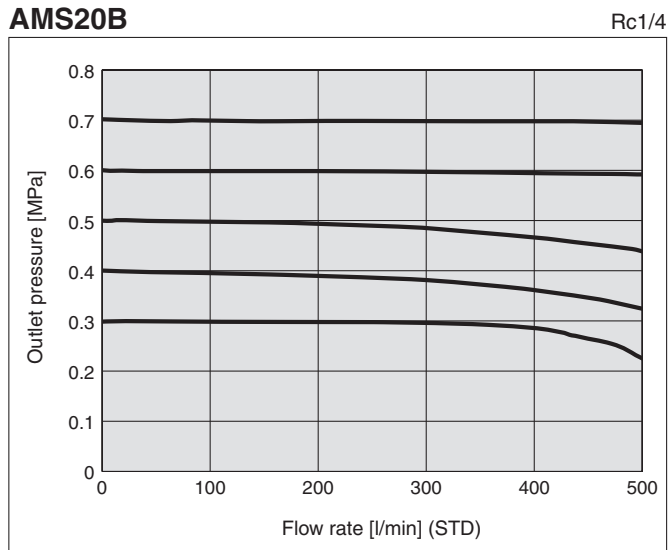

Flow Rate Characteristics (Representative values): **AMS20B/30B/40B/60B/Regulator Type**

Conditions/Supply pressure: 0.5 MPa, Standby pressure: 0.2 MPa Standby mode

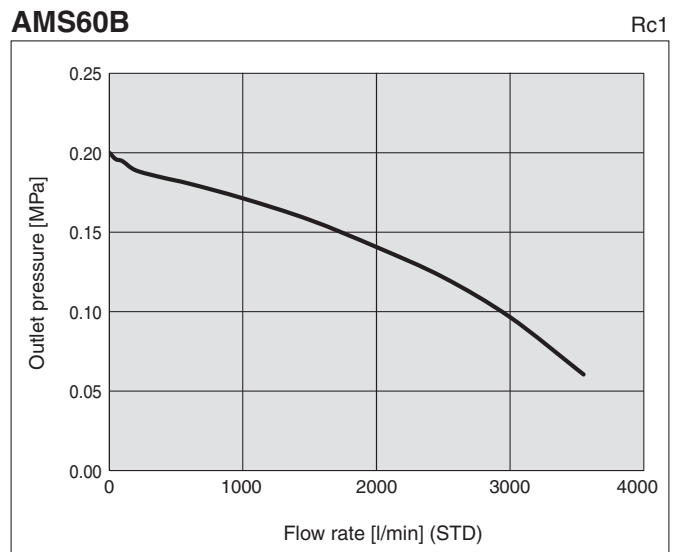
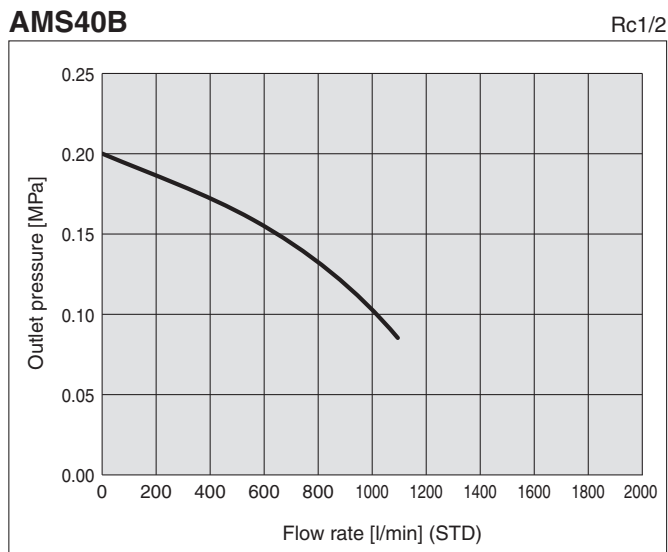
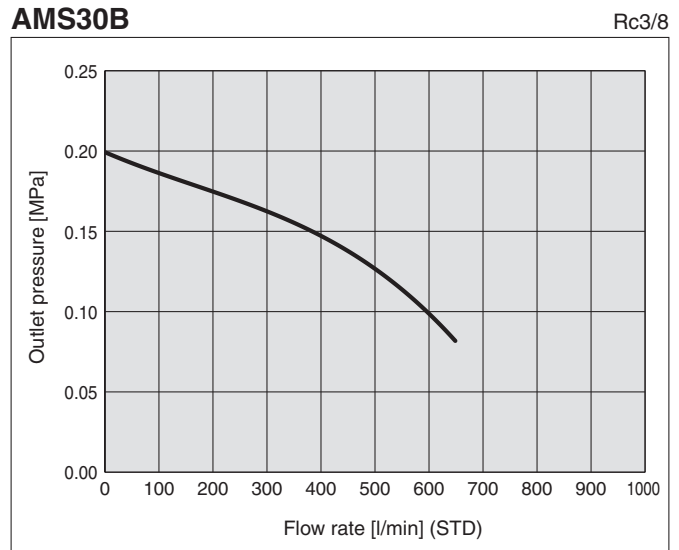
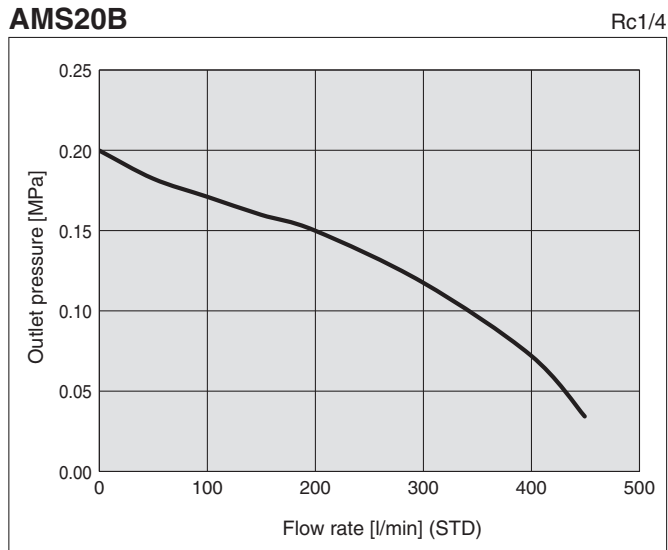

AMS20/30/40/60 Series

Dimensions: Electro-Pneumatic Regulator Type

N.C. (Normally closed)

AMS20/30/40/60A-R/N/F□C

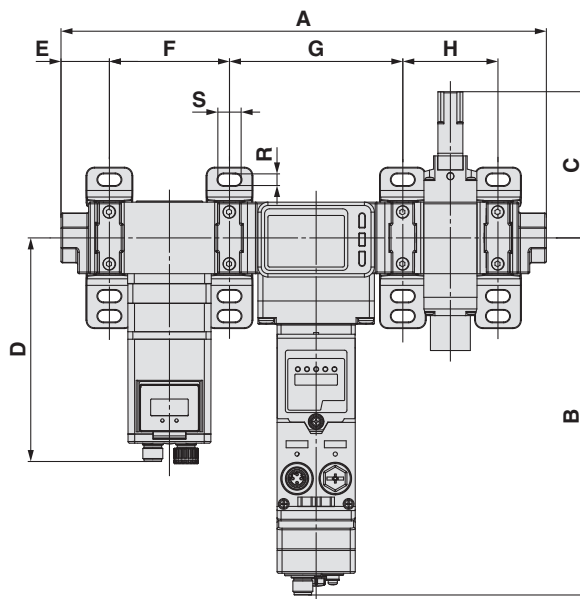
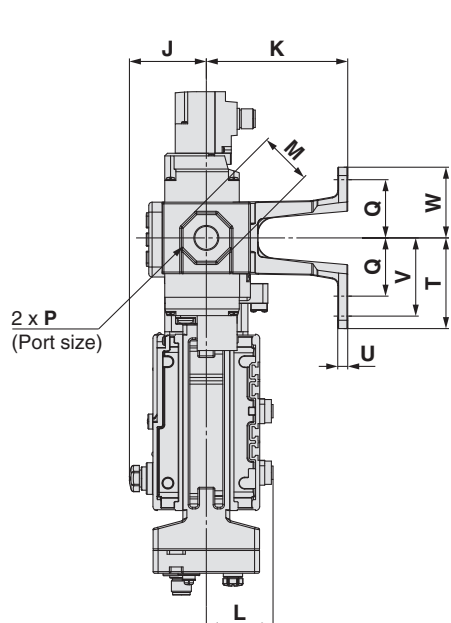

AMS20/30/40/60A-H00C

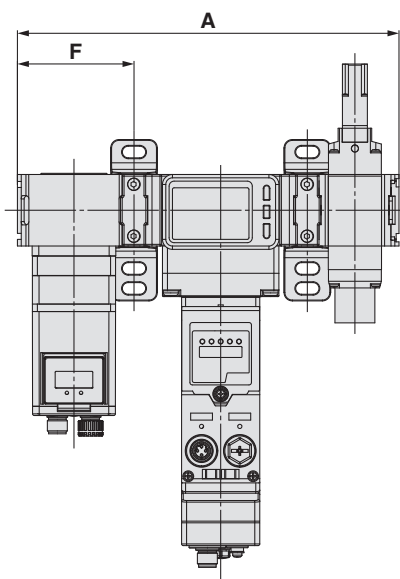

SA: Standalone
(Wireless remote)

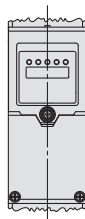

E: Push-turn locking type

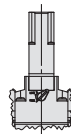

Back side

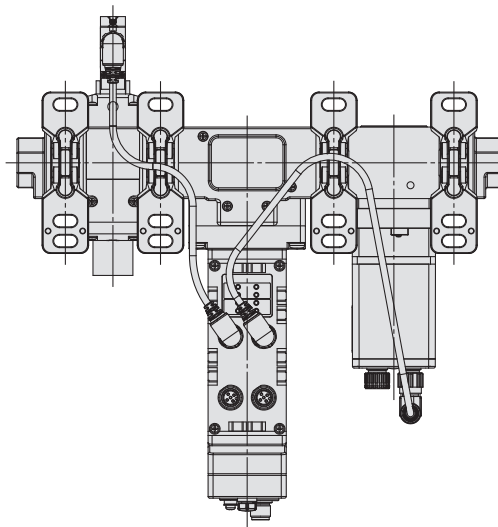

* With connection cable for standby regulator/
residual pressure relief valve

Model	P	A	B	C	D	E	J	M	L	Bracket dimensions										
										K	F	G	H	Q	R	S	T	U	V	W
AMS20A-□C	1/8, 1/4	274.3	214.7	81.7	134.4	25.6	46.2	24	40.1	85	70.2	103.2	49.7	35	7	14	54.5	6	47	42.5
AMS30A-□C	1/4, 3/8	291.8	214.7	87.9	134.4	29.1	46.2	30	40.1	85	72.2	104.2	57.2	35	7	14	54.5	6	47	42.5
AMS40A-□C	3/8, 1/2	334.8	214.9	92.4	151.6	32.6	46.2	36	40.1	85	89.2	105.2	75.2	40	9	18	65	7	55	50
AMS60A-□C	3/4, 1	401.8	214.8	93.7	151.6	42.1	46.2	46	40.1	100	90.2	126.2	101.2	50	11	20	80	8	70	60

Model	P	A	F
AMS20A-H00C	—	219.9	68.6
AMS30A-H00C	—	229.4	70.1
AMS40A-H00C	—	264.4	86.6
AMS60A-H00C	—	311.4	87.1

Dimensions: Electro-Pneumatic Regulator Type

N.O. (Normally open)

AMS20/30/40/60A-R/N/F□D

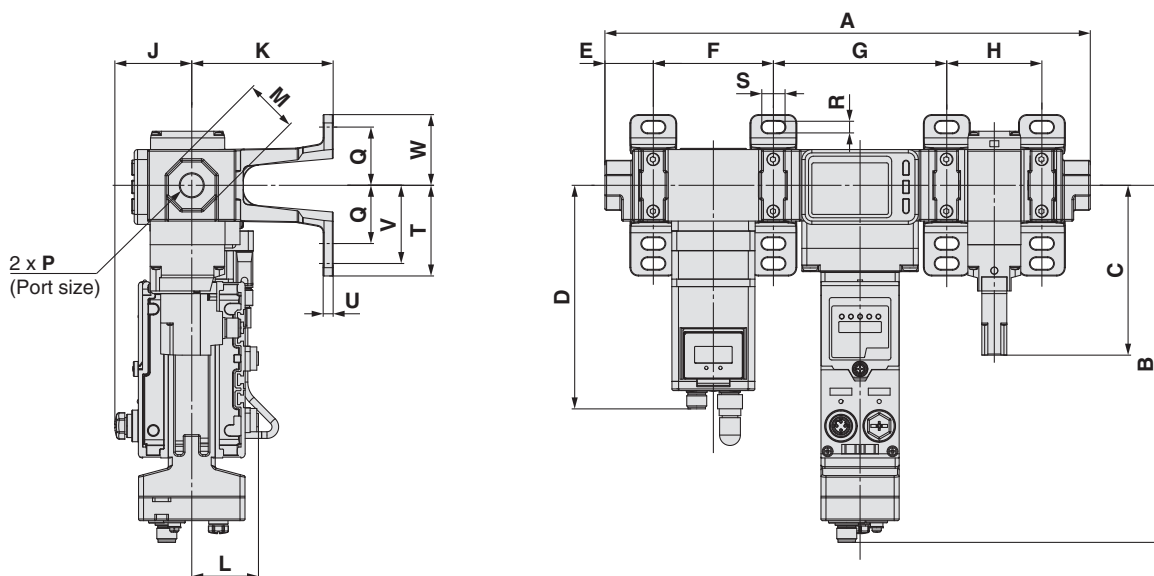

AMS20/30/40/60A-H00D

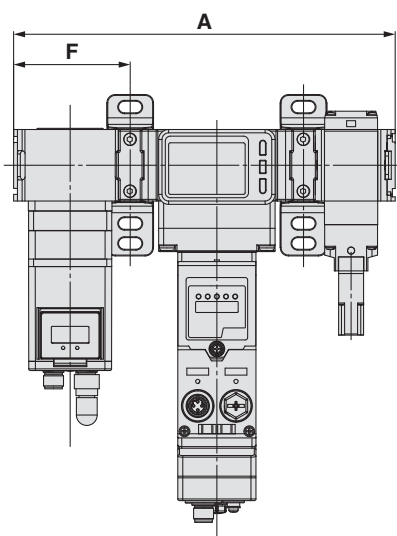

SA: Standalone
(Wireless remote)

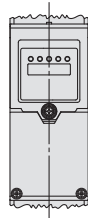

E: Push-turn locking type



Back side

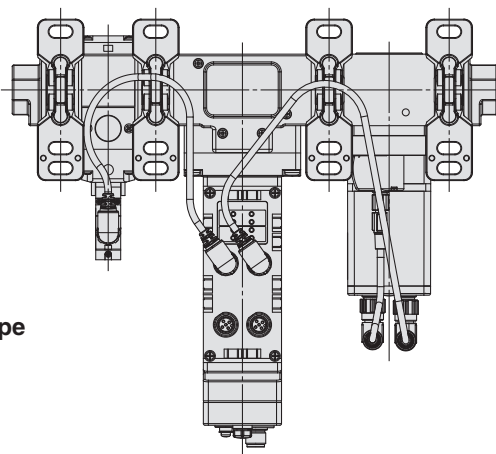

* With connection cable for standby regulator/
residual pressure relief valve

Model	P	A	B	C	D	E	J	M	L	Bracket dimensions										
										K	F	G	H	Q	R	S	T	U	V	W
AMS20A-□D	1/8, 1/4	274.3	214.7	85.1	134.4	25.6	46.2	24	40.1	85	70.2	103.2	49.7	35	7	14	54.5	6	47	42.5
AMS30A-□D	1/4, 3/8	291.8	214.7	102.1	134.4	29.1	46.2	30	40.1	85	72.2	104.2	57.2	35	7	14	54.5	6	47	42.5
AMS40A-□D	3/8, 1/2	334.8	214.9	119.4	151.6	32.6	46.2	36	40.1	85	89.2	105.2	75.2	40	9	18	65	7	55	50
AMS60A-□D	3/4, 1	401.8	214.8	117.7	151.6	42.1	46.2	46	40.1	100	90.2	126.2	101.2	50	11	20	80	8	70	60

Model	P	A	F
AMS20A-H00D	—	219.9	68.6
AMS30A-H00D	—	229.4	70.1
AMS40A-H00D	—	264.4	86.6
AMS60A-H00D	—	311.4	87.1

AMS20/30/40/60 Series

Dimensions: Regulator Type

N.C. (Normally closed)

AMS20/30/40/60B-R/N/F□C

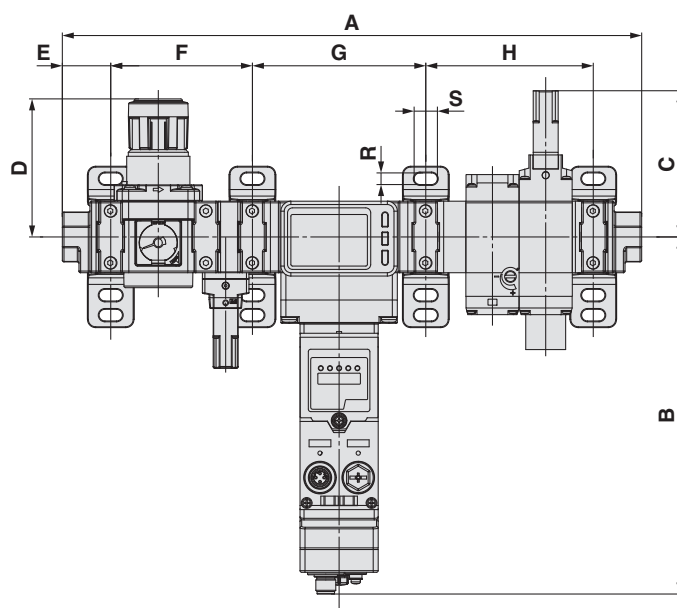
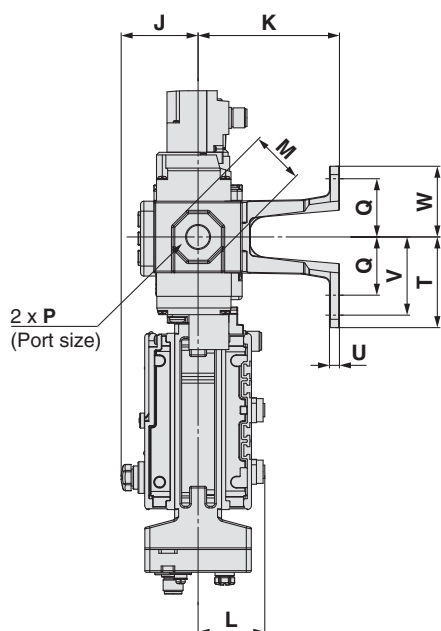

AMS20/30/40/60B-00C

SA: Standalone
(Wireless remote)

Back side

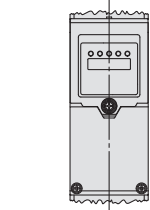
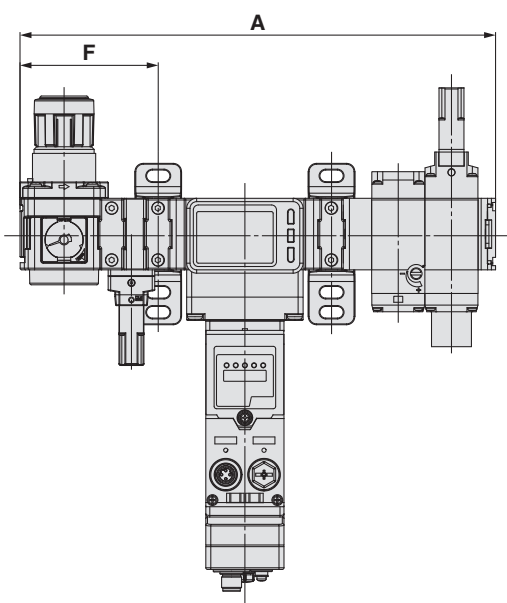

E: Push-turn locking type

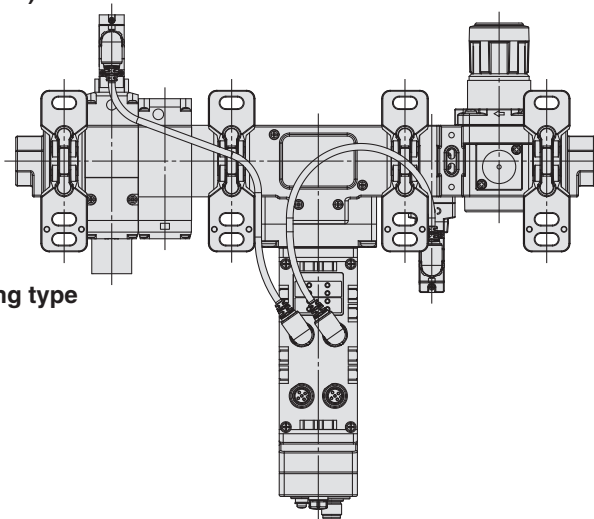
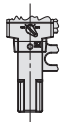

* With connection cable for standby regulator/
residual pressure relief valve

Model	P	A	B	C	D*1	E	J	M	L	Bracket dimensions										
										K	F	G	H	Q	R	S	T	U	V	W
AMS20B-□C	1/8, 1/4	301.8	214.7	81.7	66.8	25.6	46.2	24	40.1	85	71.2	103.2	76.2	35	7	14	54.5	6	47	42.5
AMS30B-□C	1/4, 3/8	348.3	214.7	87.9	86.5	29.1	46.2	30	40.1	85	85.2	104.2	100.7	35	7	14	54.5	6	47	42.5
AMS40B-□C	3/8, 1/2	395.8	214.9	92.4	91.5	32.6	46.2	36	40.1	85	103.2	105.2	122.2	40	9	18	65	7	55	50
AMS60B-□C	3/4, 1	491.8	214.8	93.4	125	42.1	46.2	46	40.1	100	124.2	126.2	157.2	50	11	20	80	8	70	60

Model	P	A	F
AMS20B-□00C	—	247.4	69.6
AMS30B-□00C	—	285.9	83.1
AMS40B-□00C	—	325.4	100.6
AMS60B-□00C	—	401.4	121.1

*1 The dimension of D is the length when the regulator knob is unlocked.

Dimensions: Regulator Type

N.O. (Normally open)
AMS20/30/40/60B-□D

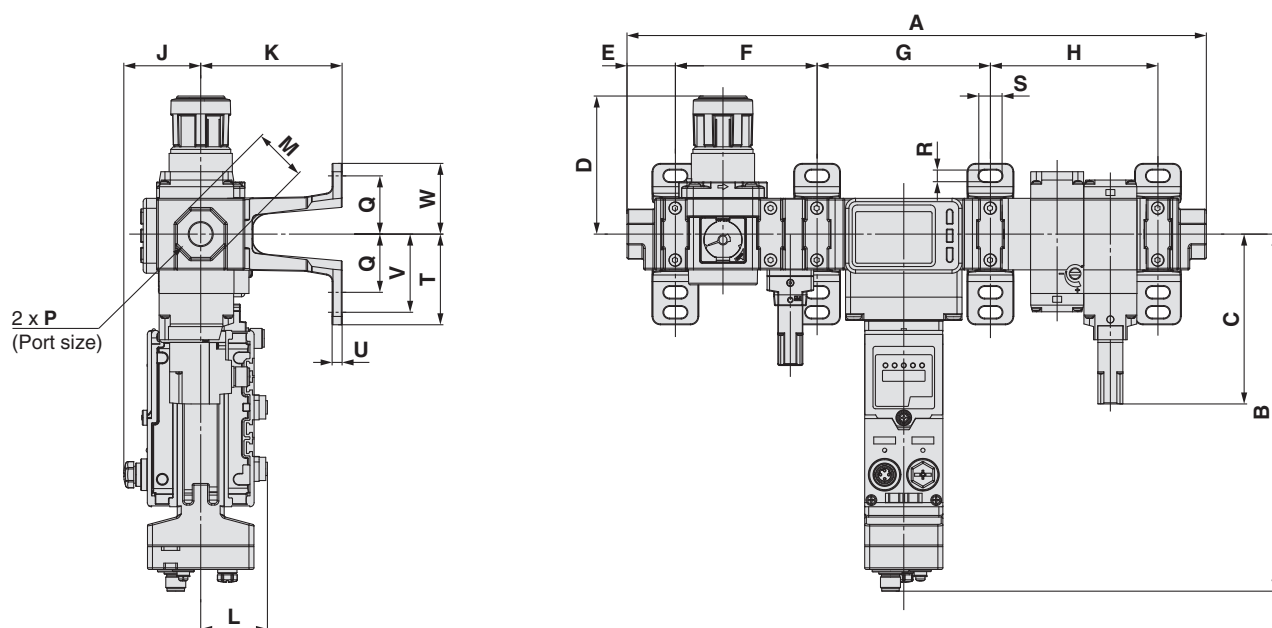

AMS20/30/40/60B-00D

SA: Standalone
(Wireless remote)

Back side

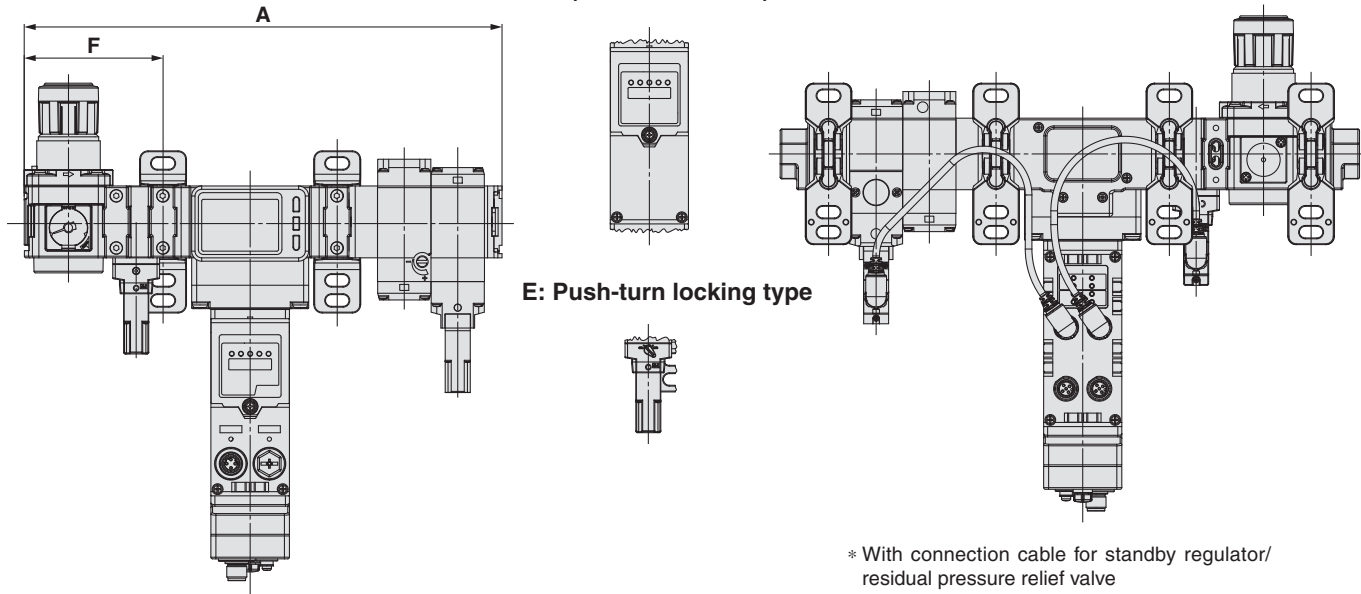

* With connection cable for standby regulator/
residual pressure relief valve

Model	P	A	B	C	D*1	E	J	M	L	Bracket dimensions										
										K	F	G	H	Q	R	S	T	U	V	W
AMS20B-□D	1/8, 1/4	301.8	214.7	85.1	66.8	25.6	46.2	24	40.1	85	71.2	103.2	76.2	35	7	14	54.5	6	47	42.5
AMS30B-□D	1/4, 3/8	348.3	214.7	102.1	86.5	29.1	46.2	30	40.1	85	85.2	104.2	100.7	35	7	14	54.5	6	47	42.5
AMS40B-□D	3/8, 1/2	395.8	214.9	119.4	91.5	32.6	46.2	36	40.1	85	103.2	105.2	122.2	40	9	18	65	7	55	50
AMS60B-□D	3/4, 1	491.8	214.8	118	125	42.1	46.2	46	40.1	100	124.2	126.2	157.2	50	11	20	80	8	70	60

Model	P	A	F
AMS20B-□00D	—	247.4	69.6
AMS30B-□00D	—	285.9	83.1
AMS40B-□00D	—	325.4	100.6
AMS60B-□00D	—	401.4	121.1

*1 The dimension of D is the length when the regulator knob is unlocked.

Air Management Hub

EXA1 Series



How to Order

EXA1 - **40** - **SA** - **M** L

① ② ③

	Symbol	Description	①			
			Body size [Applicable AC size]			
			20	30	40	60
② Protocol	SA	Standalone (When wireless adapter is connected: Wireless remote)	●	●	●	●
	PN	PROFINET, OPC UA (When wireless adapter is connected: Wireless base)	●	●	●	●
	EN	EtherNet/IP™, OPC UA (When wireless adapter is connected: Wireless base)	●	●	●	●
③ Unit	K	Units selection function	●	●	●	●
	M*1	SI units only	●	●	●	●

*1 Fixed units Instantaneous flow: l/min, Accumulated flow: L, Pressure: kPa/MPa, Temperature: °C

All Protocols Common Specifications

Model		EXA1-20	EXA1-30	EXA1-40	EXA1-60		
Fluid	Measured fluid*1	Air					
	Fluid temperature	0 to 50 °C					
Electrical	Power supply voltage	24 VDC ±10 %					
	Protection	Polarity protection, Over current protection					
	Current consumption	400 mA					
	Indicator	LED & LCD					
Environment	Operating temperature range	0 to 50 °C (No freezing and condensation)					
	Storage temperature range	-10 to 60 °C (No freezing and condensation)					
	Enclosure	IP65 (Electrical equipment part only)					
	Standards	CE/UKCA marking					
Flow	Rated flow range	5 to 500 l/min	10 to 1000 l/min	20 to 2000 l/min	40 to 4000 l/min		
	Accumulated flow range	0 to 9,999,999,990 L					
	Smallest settable increment	Instantaneous flow	1 l/min		2 l/min		
		Accumulated flow	10 L				
	Accuracy	±3.0 % F.S.					
	Repeatability	±1.0 % F.S.					
Pressure characteristics	±5.0 % F.S. (0 to 1.0 MPa, 0.5 MPa standard)						
Pressure	Temperature characteristics	±5.0 % F.S. (0 to 50 °C, 25 °C standard)					
	Unit	l/min, CFM (ft³/min)					
	Rated pressure range	0 to 1.0 MPa					
	Proof pressure	1.5 MPa					
	Accuracy	±3.0 % F.S.					
	Repeatability	±1.0 % F.S.					
Temperature	Temperature characteristics	±5.0 % F.S. (0 to 50 °C, 25 °C standard)					
	Unit	MPa, kPa, kgf/cm², bar, psi					
	Rated temperature range	0 to 50 °C					
	Accuracy*2	±2.5 °C (Flow range: 10 % to 100 %)					
Input/Output	User configurable port	Number of free ports	1				
		Configuration	Digital input (x 2), Digital input and output, IO-link and digital input				
	Port specifications	IO-Link	Communication speed	COM1 (4.8 kbps) COM2 (38.4 kbps) COM3 (230.4 kbps) Automatically switches depending on the connected device			
			Max. supply current	0.3 A			
			Input type	PNP			
			Rated input current	Pin 2: Typ. 2.5 mA, Pin 4: Typ. 5.8 mA			
		Input	ON voltage	13 V or more			
			OFF voltage	8 V or less			
			Output type	PNP			
				Max. load current	0.25 A		
			Output for Air Management System function		IO-Link/PNP input/PNP output		
			Weight		750 g	770 g	810 g

Protocol specifications (EXA1-□-PN)

Model		EXA1-□-PN	
Communication	Protocol	PROFINET IO (Conformance Class C)	
	Communication speed	100 Mbps	
	Configuration file	GSDML file*3	
	Web server	Support	
Input/Output	Output	Fail safe	HOLD/CLEAR

*3 The configuration file can be downloaded from the SMC website.
<https://www.smc.eu>

Protocol specifications (EXA1-□-EN)

Model		EXA1-□-EN	
Communication	Number of communication ports	2 port	
	Protocol	EtherNet/IP™ (Conformance version: Composite 11)	
	Communication speed	100 Mbps	
	Communication method	Full duplex/Half duplex	
	Configuration file	EDS file*3	
	Occupation area (Number of inputs/outputs)	Max. (512 byte/512 byte)	
	IP address setting range	Through DHCP server: Optional address	
	Device information	Vendor ID : 7(SMC Corporation)	
		Device type : 12 (Communication Adapter) Product code : 263	
	Web server	Support	
Input/Output	Output	Fail safe	HOLD/CLEAR

*3 The configuration file can be downloaded from the SMC website.
<https://www.smc.eu>

*1 Air quality grade is JIS B 8392-1:2012 [4:6:-] and ISO 8573-1:2010 [4:6:-].

*2 When the flow range is less than 10 %, temperature accuracy is -2.5 to 7.5 °C.

Dimensions: **Sizes 20, 30, 40**

EXA1-20/30/40-PN/EN-□

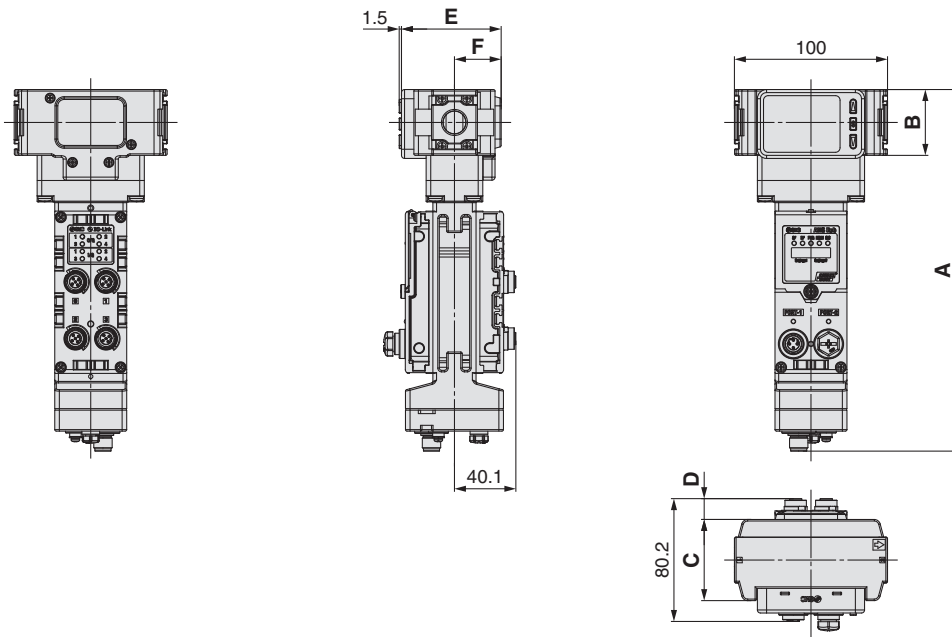

Model	A	B	C	D	E	F
EXA1-20	236.2	35	42	19.1	65.1	30.5
EXA1-30	236.2	43	53	13.6	65.1	30.5
EXA1-40	240.4	51	71	4.6	71	35.5

EXA1-20/30/40-SA-□

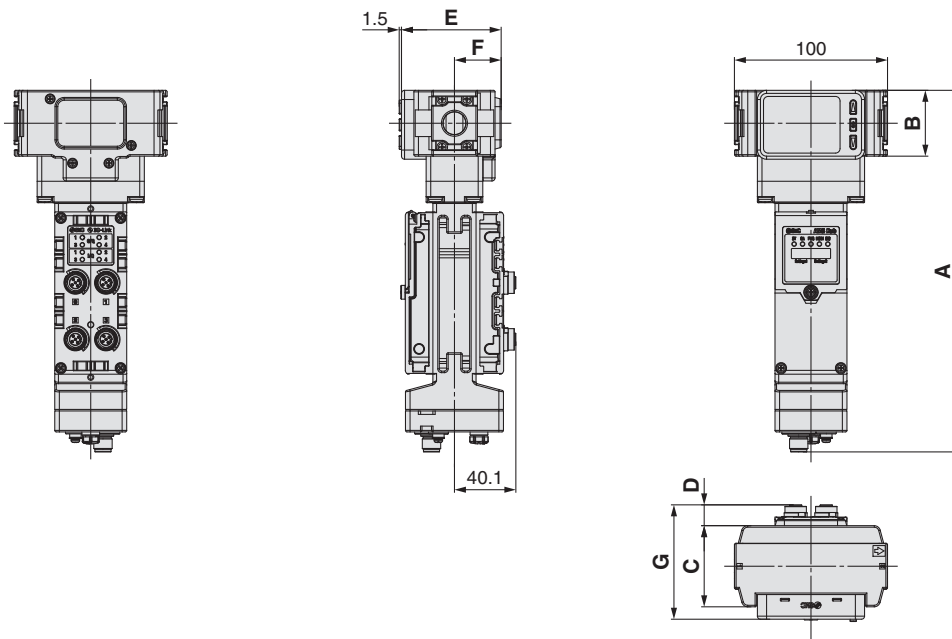

Model	A	B	C	D	E	F	G
EXA1-20	236.2	35	42	19.1	65.1	30.5	74.7
EXA1-30	236.2	43	53	13.6	65.1	30.5	74.7
EXA1-40	240.4	51	71	4.6	71	35.5	75.6

EXA1 Series

Dimensions: **Size 60**

EXA1-60-PN/EN-□

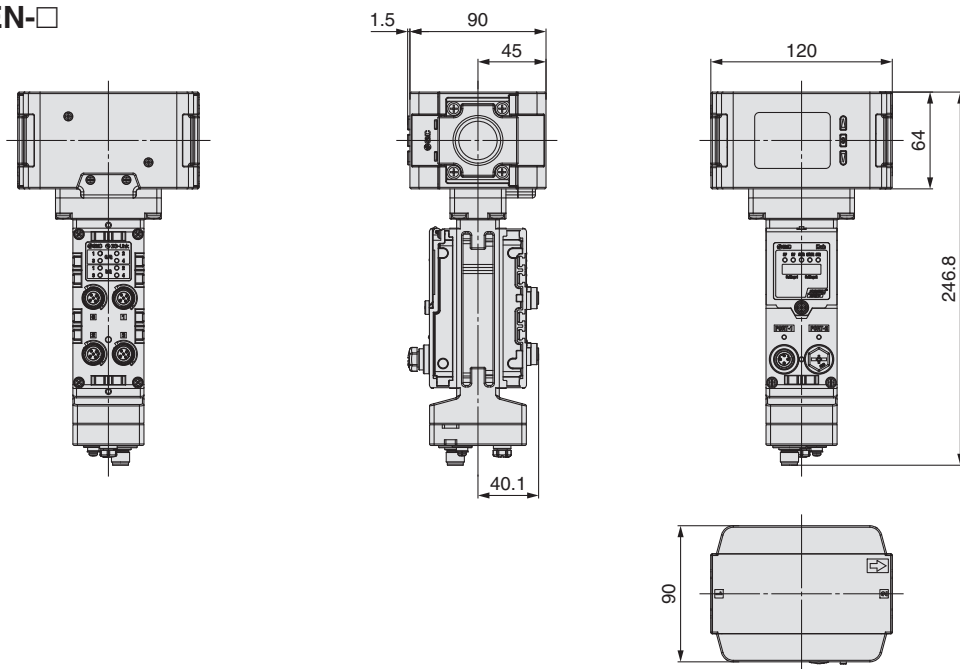

EXA1-60-SA-□

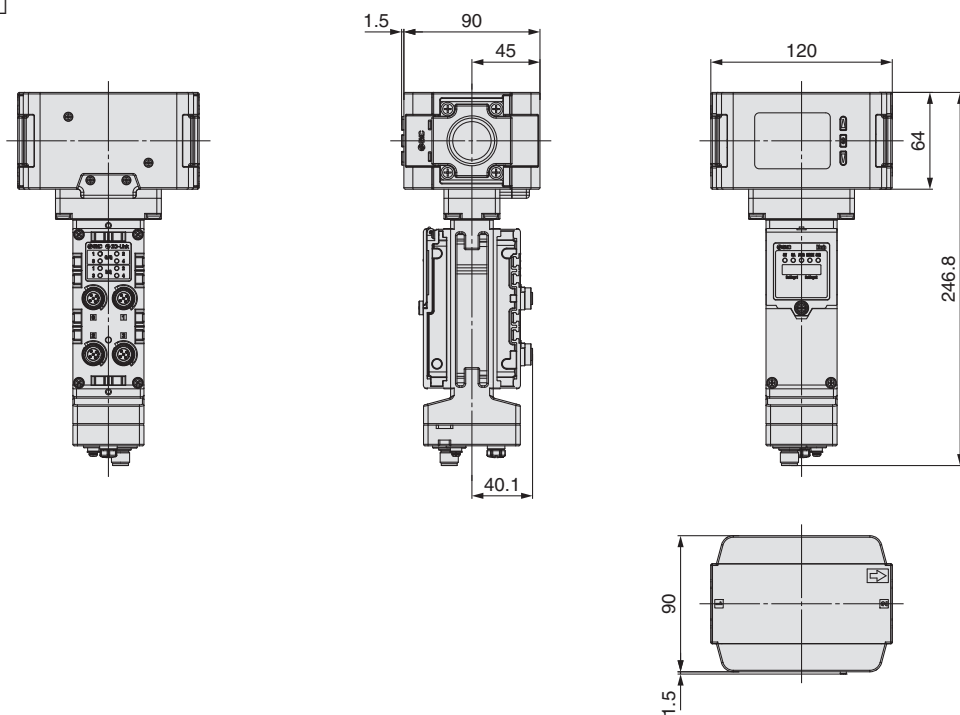

Standby Electro-Pneumatic Regulator ITV2050 to 3050-X399

Symbol

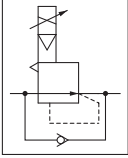

How to Order

For AMS20A	ITV20	50	-IL	20	-	1	-	K	-	X399
For AMS30A	ITV20	50	-IL	30	-	1	-	K	-	X399
For AMS40A	ITV30	50	-IL	40	-	1	-	K	-	X399
For AMS60A	ITV30	50	-IL	60	-	1	-	K	-	X399
		① ②		③ ④		⑤		⑥		

① Pressure range	② Power supply voltage	③ Input signal	④ Applicable AMS□A size
5 0.005 to 0.7 MPa	0 24 VDC ±10 %	IL IO-Link	20 For AMS20A
⑤ Type of actuation	⑥ Pressure display unit		30 For AMS30A
1 Normally closed	K Units selection function		40 For AMS40A
2 Normally open*2	M SI units only*6		60 For AMS60A

Specifications

Applicable AMS series		AMS20A	AMS30A	AMS40A	AMS60A
Min. supply pressure		Set pressure ±0.1 MPa			
Max. supply pressure		0.8 MPa			
Set pressure range (Rated)*1		0.005 to 0.7 MPa			
Power supply	Voltage	24 VDC ±10 %			
	Current consumption	0.12 A or less			
Communication	Protocol	IO-Link			
	Version	VERSION 1.1			
	Communication speed	230.4 kbps (COM3)			
	IO-Link port	CLASS A			
	IO-Link type	Device			
Linearity		±1% F.S. or less*4			
Repeatability		±0.5 % F.S. or less			
Sensitivity		0.2 % F.S. or less			
Temperature characteristics		±0.12 % F.S./°C or less			
Output pressure display	Accuracy	±2 % F.S. ±1 digit or less			
	Min. unit*5	3 digits MPa: 0.001, 2 digits MPa: 0.01, kgf/cm ² : 0.01, bar: 0.01, psi: 1, kPa: 1			
Ambient and fluid temperatures		0 to 50 °C (No condensation)			
Enclosure		IP65			
Weight (Without accessories)		727 g	780 g	1320 g	1640 g

*1 This product does not exhaust by itself. It is not possible to decrease the output pressure with this product alone. (Except when supply pressure is shut off)
 *2 In the case of the normally open specification, the output pressure is the supply pressure minus 0.1 MPa or more when the product is turned off.
 *3 This product will reduce output pressure to 0.005 MPa or less if the secondary side output is present when supply pressure is shut off.
 *4 Since this product does not exhaust by itself, it does not meet product specifications if there is no pressure drop or overshoot.
 *5 If the unit is fixed to SI, only MPa or kPa will be displayed.
 *6 For use in Japan, the product fixed to SI unit must be used to comply with the new Measurement Act.
 *7 This product is for AMS20A/30A/40A/60A only. Do not use for any other application.

ITV2050 to 3050-X399

Dimensions: **Sizes 20, 30**

N.C. (Normally closed)
ITV2050-□20/30-□-X399

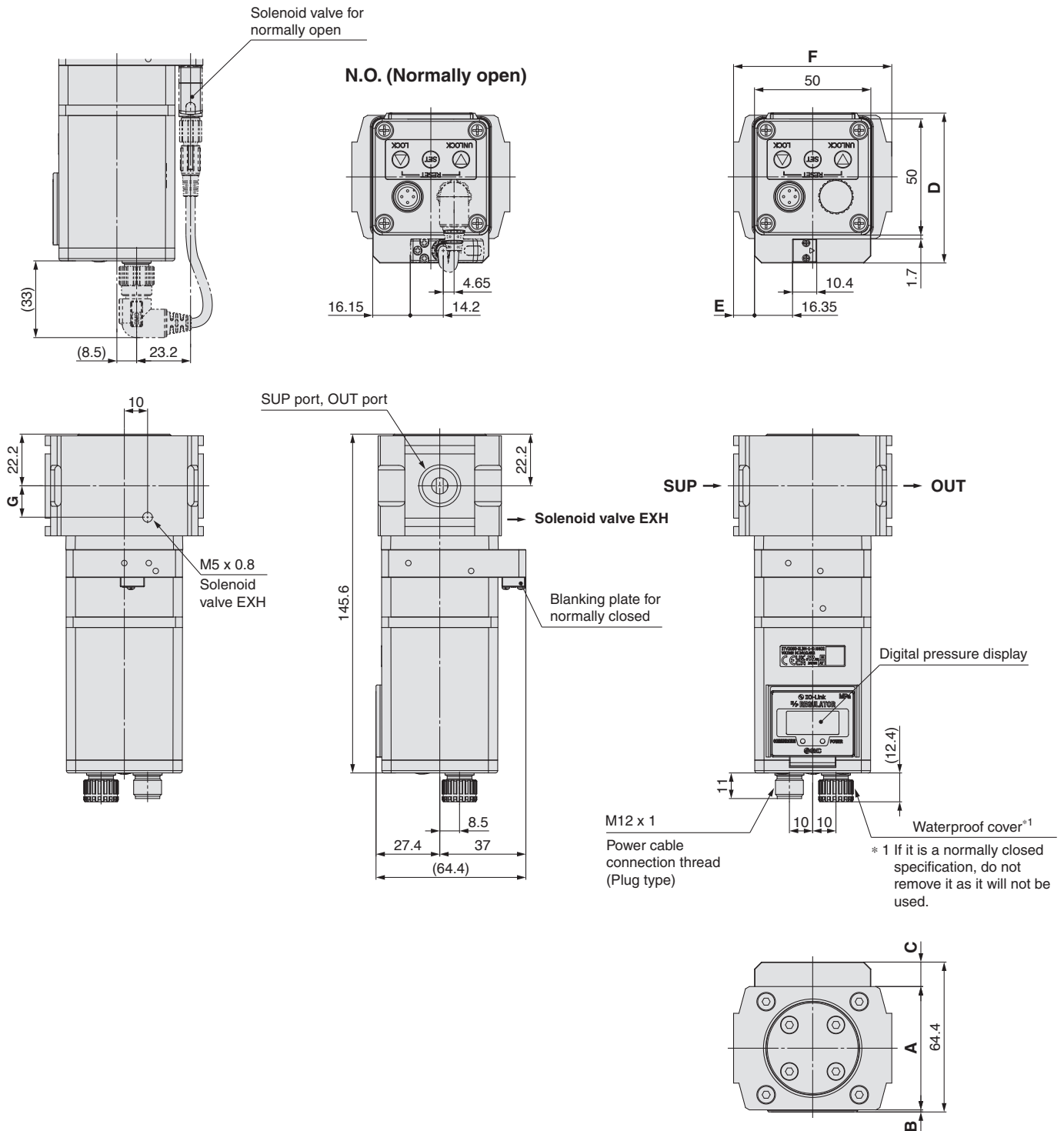

Model	A	B	C	D	E	F	G
ITV2050-20-□-X399	50	2.4	11.8	64.5	8.5	67	12.5
ITV2050-30-□-X399	53	0.9	10.5	64.4	9	68	13.5

Standby Electro-Pneumatic Regulator *ITV2050 to 3050-X399*

Dimensions: **Sizes 40, 60**

N.C. (Normally closed)
ITV3050-□40/60-□-X399

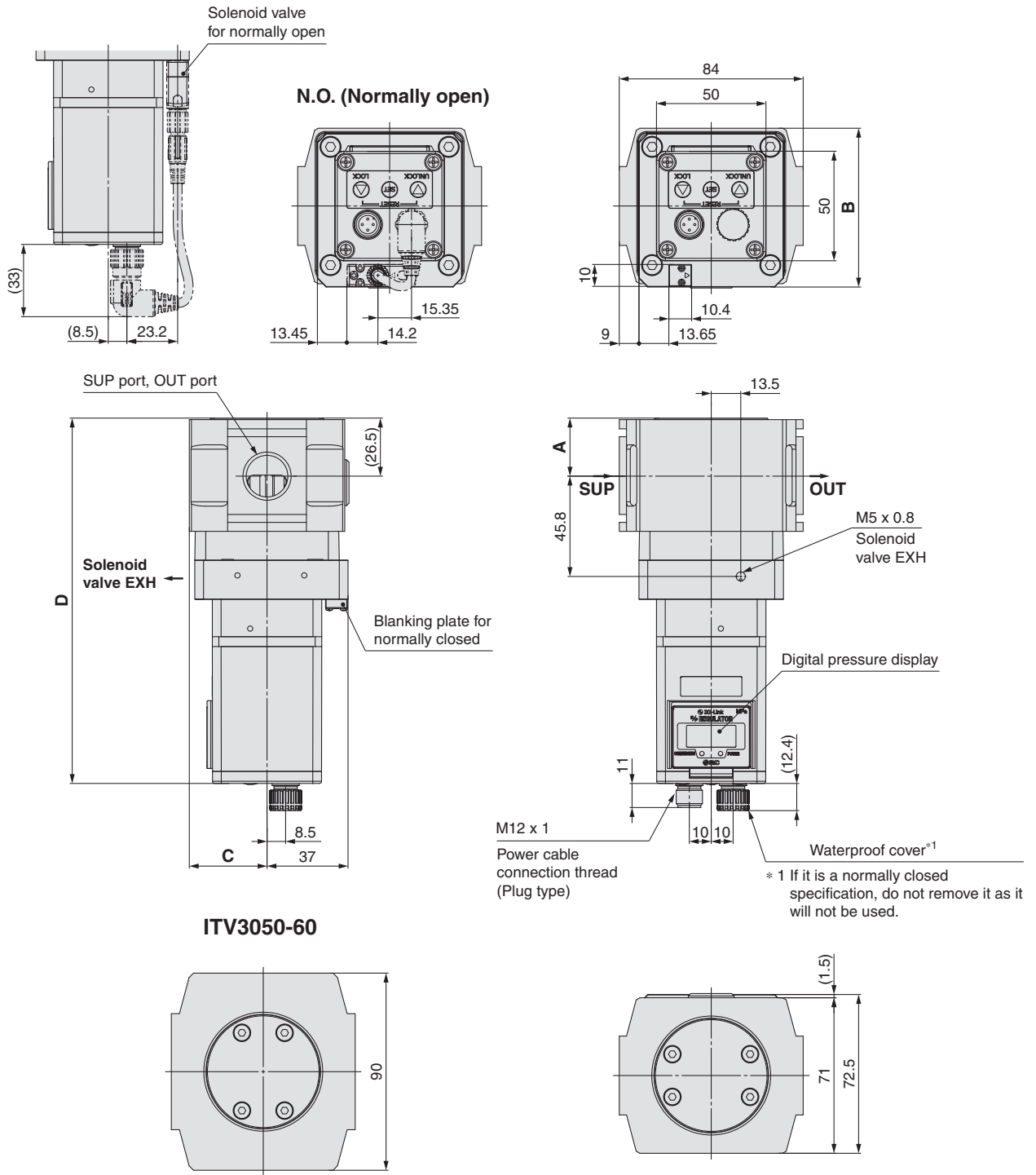

Model	A	B	C	D
ITV3050-40-□-X399	26.5	72.5	35.5	166.8
ITV3050-60-□-X399	33	90	45	173.6

Standby Regulator



AR20S to 50S Series

Symbol

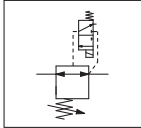

How to Order

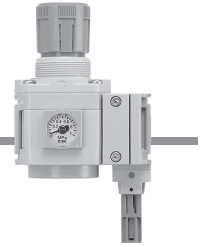

AR **30** S - **F** **03** E - Y **15V**

①
②
③
④
⑤

	Symbol	Description	① Body size			
			20	30	40	50
② Pipe thread type	—	Rc	●	●	●	●
	N	NPT	●	●	●	●
	F	G	●	●	●	●
+						
③ Port size (Screws are IN side only.)	02	1/4	●	—	—	—
	03	3/8	—	●	—	—
	04	1/2	—	—	●	—
	10	1	—	—	—	●
+						
Pressure gauge	E	Square embedded type pressure gauge (with limit indicator)	●	●	●	●
+						
Knob	Y	Upward	●	●	●	●
+						
④ Unit	—	Name plate and pressure gauge in SI units: MPa	●	●	●	●
	Z	Name plate: MPa, Pressure gauge: MPa/psi dual scale	●	●	●	●
+						
Solenoid valve mounting position and electrical entry direction	1	Mounting position: Opposite side of the knob, Entry direction: Rear side	●	●	●	●
+						
Rated voltage	5	24 VDC	●	●	●	●
+						
Electrical entry	V	M12 connector	●	●	●	●
+						
Light/surge voltage suppressor	—	With light/surge voltage suppressor	●	●	●	●
+						
⑤ Manual override	—	Non-locking push type	●	●	●	●
	E	Push-turn locking type (Manual)	●	●	●	●

Specifications

Model	AR20S	AR30S	AR40S	AR50S
Port size	1/4	3/8	1/2	1
Fluid	Air			
Ambient and fluid temperatures	0 to 50 °C			
Proof pressure	1.05 MPa			
Max. operating pressure	0.7 MPa			
Set pressure range	0.2 to 0.4 MPa			
Regulator exhaust construction	Non-relieving type			
Pilot valve exhaust method	Individual exhaust			
Lubrication	Not required			
Impact/Vibration resistance*1	150/30 m/s ²			
Enclosure	IP65 (Electrical equipment part only)			
Weight	0.30 kg	0.49 kg	0.77 kg	1.49 kg

*1 Impact resistance: No malfunction occurred when it is tested in the axial direction and at the right angles to the main valve and armature in both energised and de-energised states every once for each condition. (Values at the initial period)
 Vibration resistance: No malfunction occurred in a one-sweep test between 45 and 2000 Hz. The test was performed at both energised and de-energised states in the axial direction and at the right angles to the main valve and armature. (Values at the initial period)

Solenoid Specifications

Coil rated voltage	24 VDC
Allowable voltage fluctuation	±10 % of the rated voltage
Power consumption	0.4 W
Surge voltage suppressor	Diode
Indicator light	LED

Dimensions

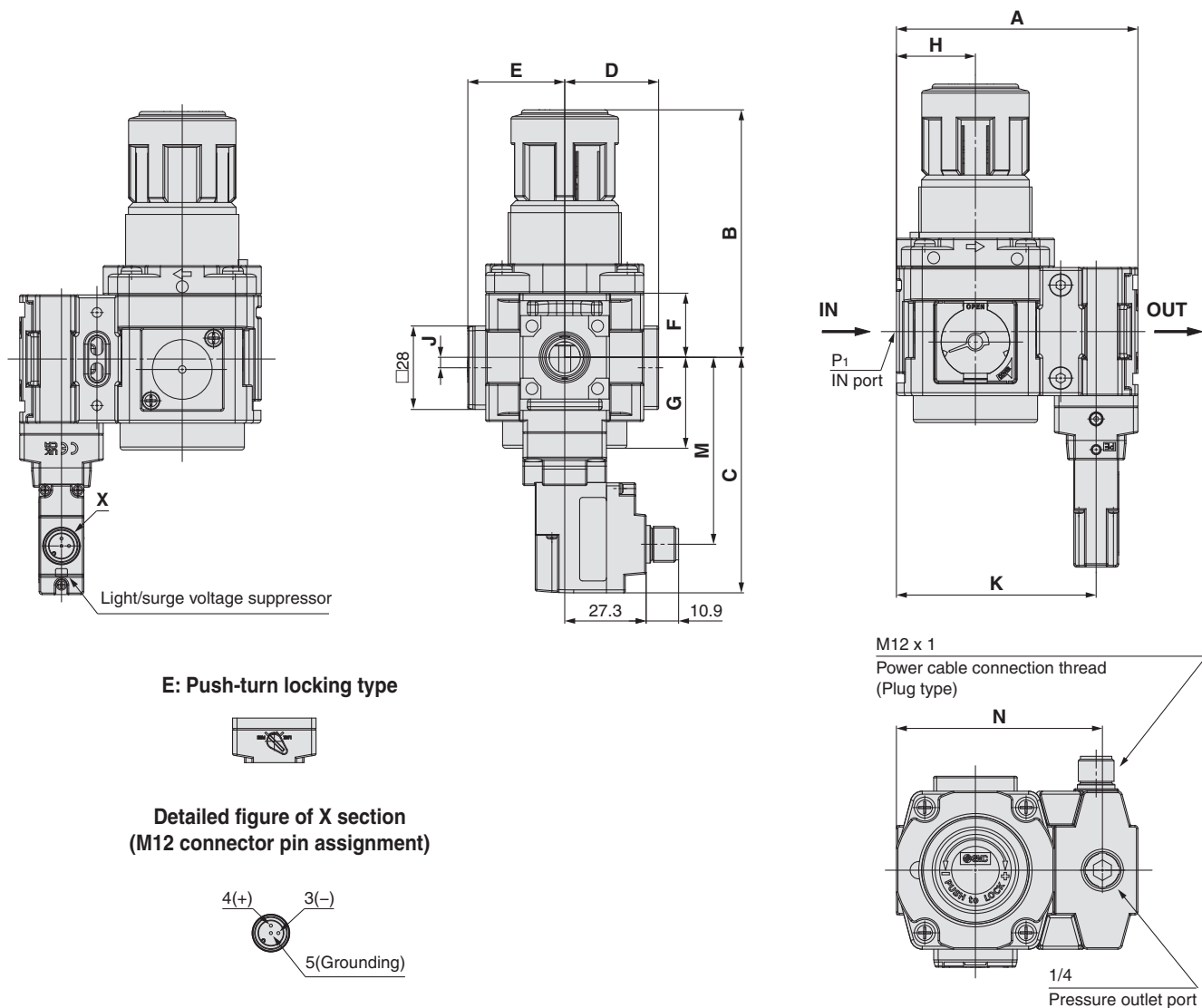

Model	P1	A	B*1	C	D	E	F	G	H	J	K	M	N
AR20S	1/4	68	66.8	73	26	27	17.5	26.5	20	2	54	56.7	55.6
AR30S	3/8	81	86.5	79	31.5	32.5	21.5	30.5	26.5	3.5	67	62.7	69.1
AR40S	1/2	98	91.5	83	40.5	41.5	25.5	35.5	35	—	84	66.7	86.6
AR50S	1	118	125	90.5	50	51	32	43	45	—	104	74.2	105

*1 The dimension of B is the length when the regulator knob is unlocked.

Residual Pressure Relief 3-Port Solenoid Valve

VP346E/546E/746E/946E-X660/X661

How to Order

VP **3** 46 E - **5** **KVO** Z **1** - **X660**

① ② ③ ④ ⑤ ⑥ ⑦ ⑧

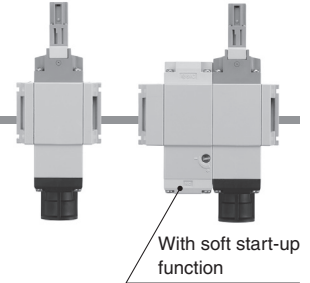

① Series

3	VP300
5	VP500
7	VP700
9	VP900

②

E	Residual pressure relief 3-port solenoid valve
---	------------------------------------------------

③ Rated voltage

5	24 VDC
---	--------

④ M12 connector

	Pin assignment	Series			
		VP300	VP500	VP700	VP900
KO	Without connector	—	—	—	●
KVO	Without connector	●	●	●	—

⑤ Light/surge voltage suppressor

Z	With light/surge voltage suppressor
---	-------------------------------------

⑥ Manual override

—	Non-locking push type
E	Push-turn locking type (Manual)

⑦ Soft start-up function

—	None
S	With soft start-up function

⑧ Type of actuation

X660	N.C. (Normally closed)
X661	N.O. (Normally open)

Specifications

Model	VP346E	VP546E	VP746E	VP946E	
Fluid	Air				
Type of actuation	N.C. (X660)/N.O. (X661)				
Operating pressure range	0.2 to 0.7 MPa				
Ambient and fluid temperatures	-10 to 50 °C (No freezing)				
Max. operating frequency*1	VP(3,5,7)46E	5 Hz			
	VP946E	1 Hz			
Manual override	Non-locking push type Push-turn locking type (Manual)				
Pilot exhaust	Individual exhaust				
Lubrication	Not required				
Impact/Vibration resistance*2	150/30 m/s ²				
Enclosure	IP65 (Electrical equipment part only)				
Weight	None	210 g	340 g	710 g	1410 g
	With soft start-up function	310 g	600 g	1260 g	2300 g

*1 Excludes the type with a soft start-up function

*2 Impact resistance: No malfunction occurred when it is tested in the axial direction and at the right angles to the main valve and armature in both energised and de-energised states every once for each condition. (Values at the initial period)

Vibration resistance: No malfunction occurred in a one-sweep test between 45 and 2000 Hz. The test was performed at both energised and de-energised states in the axial direction and at the right angles to the main valve and armature. (Values at the initial period)

* This valve is a large flow rate pilot-operated solenoid valve. If the operating pressure falls below 0.2 MPa due to a pressure drop caused by insufficient air supply, it may not be able to switch properly.

Solenoid Specifications

Coil rated voltage	24 VDC
Allowable voltage fluctuation	±10 % of the rated voltage
Power consumption	0.4 W
Surge voltage suppressor	Diode
Indicator light	LED

Dimensions

N.C. (Normally closed)
VP346E-X660

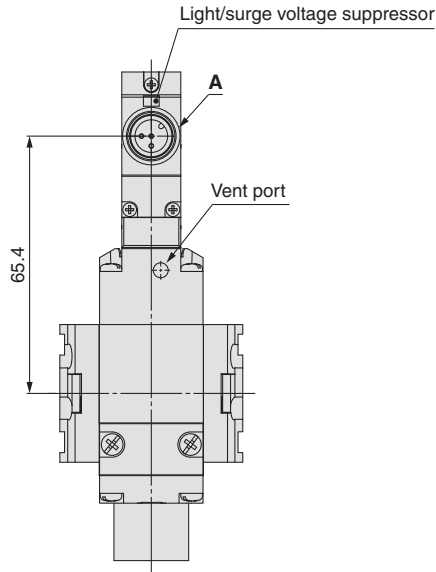

**Detailed figure of A section
M12 connector**

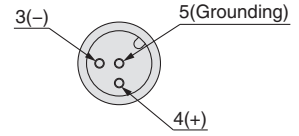

**Details of manual override part
(for manual operation)
Type E**

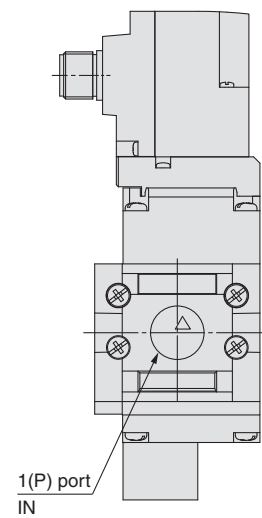
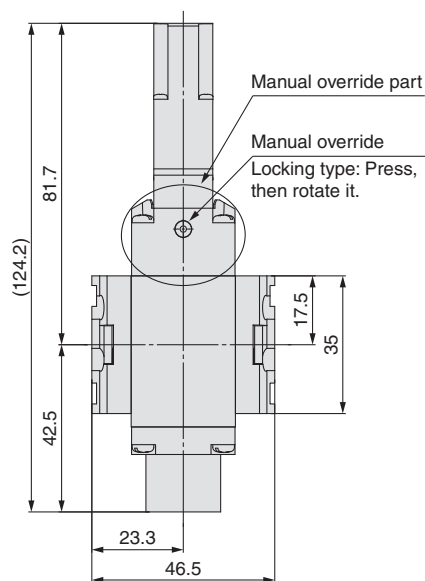
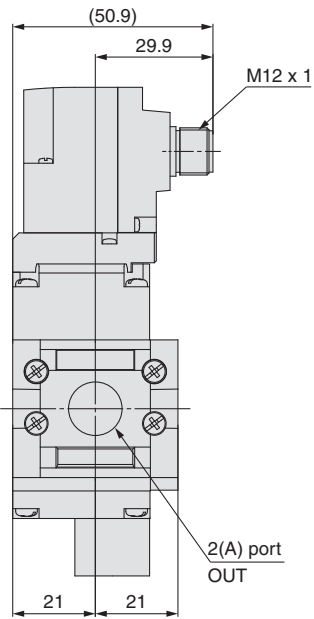
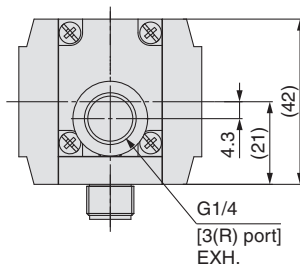
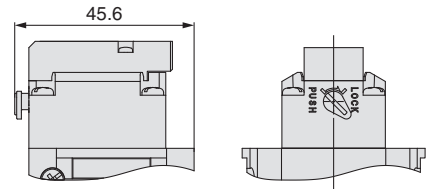

VP346E/546E/746E/946E-X660/X661

Dimensions

N.O. (Normally open)
VP346E-X661

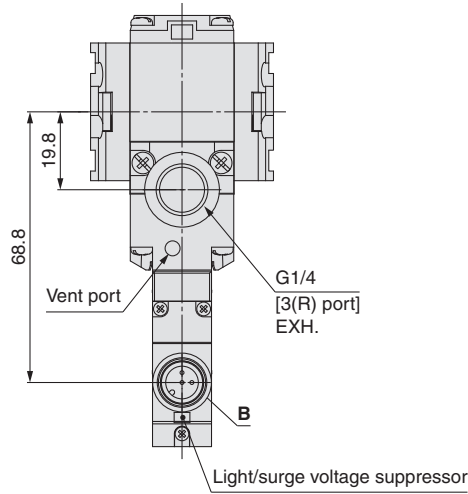

Detailed figure of B section
M12 connector

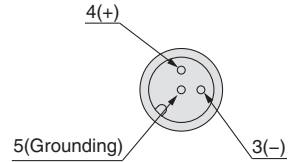

Details of manual override part
(for manual operation)
Type E

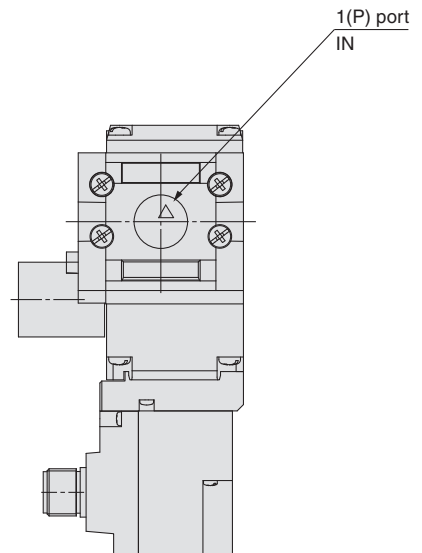
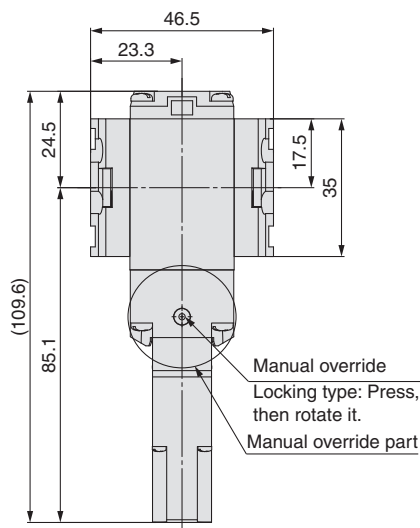
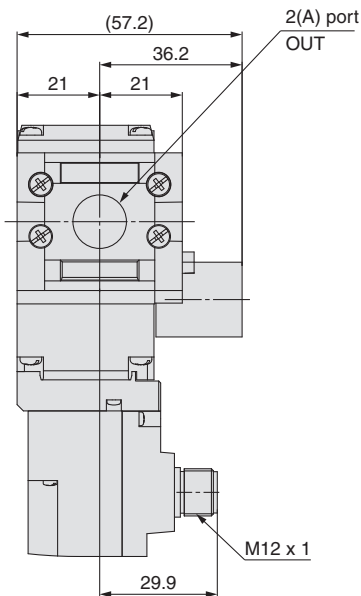
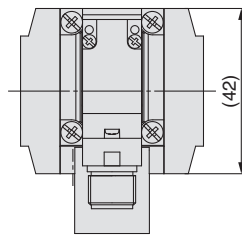
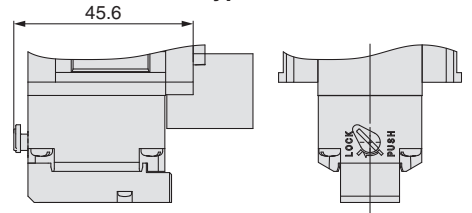

Dimensions

With soft start-up function
N.C. (Normally closed)
VP346E-S-X660

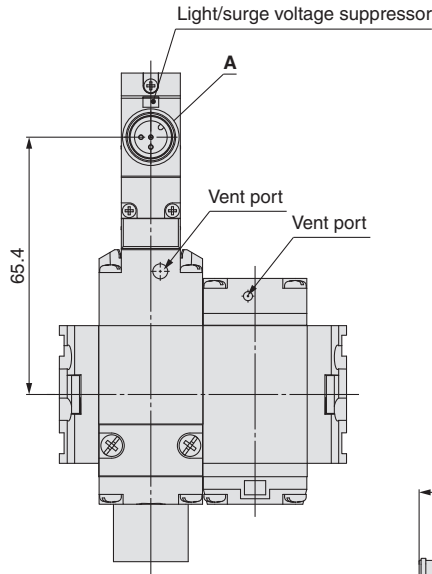

Detailed figure of A section
M12 connector

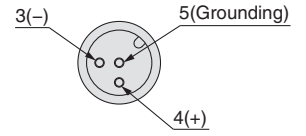

Details of manual override part
(for manual operation)
Type E

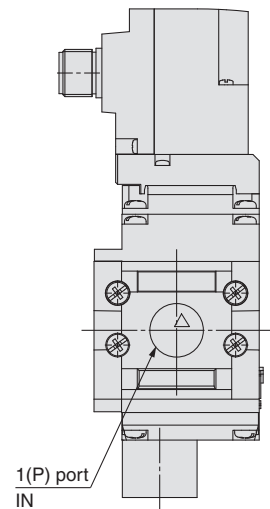
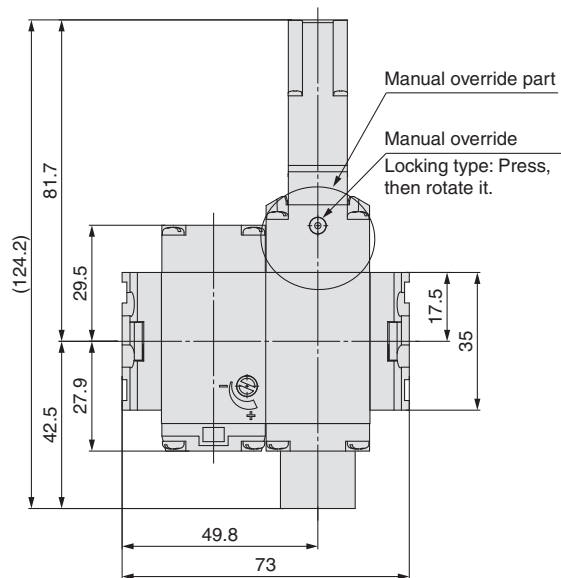
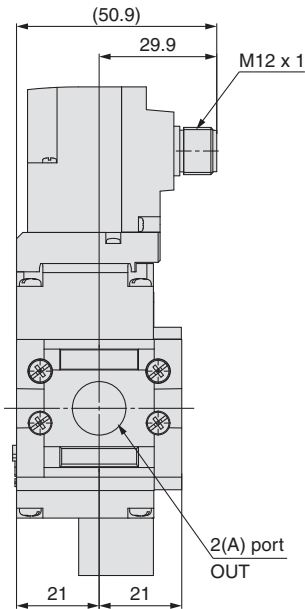
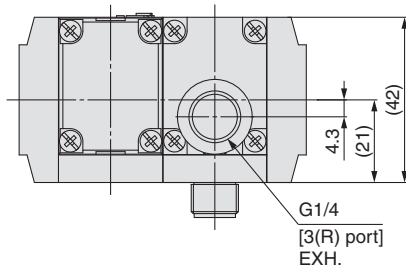
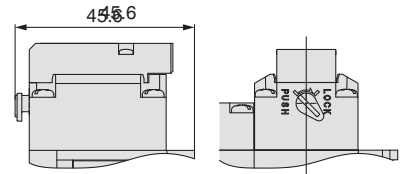

VP346E/546E/746E/946E-X660/X661

Dimensions

With soft start-up function
 N.O. (Normally open)
 VP346E-S-X661

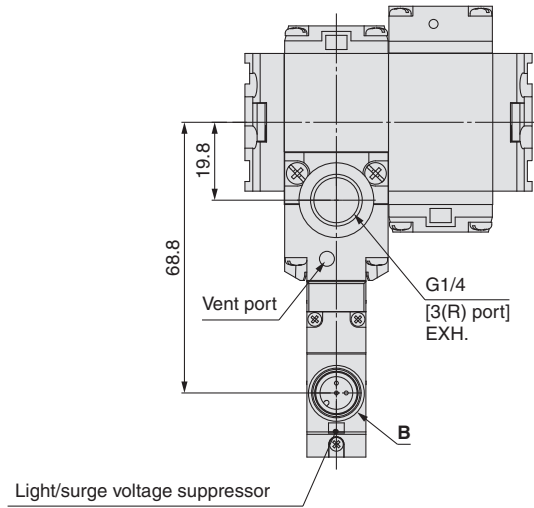

Detailed figure of B section
 M12 connector

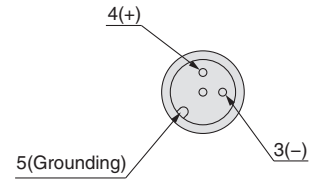

Details of manual override part
 (for manual operation)
 Type E

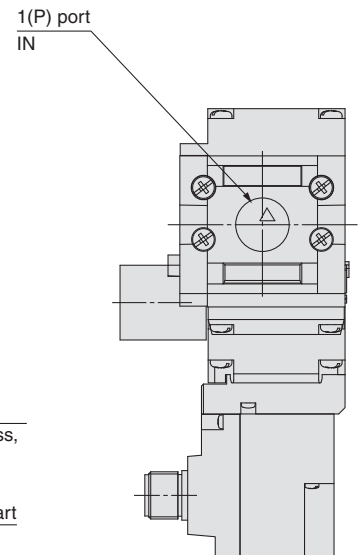
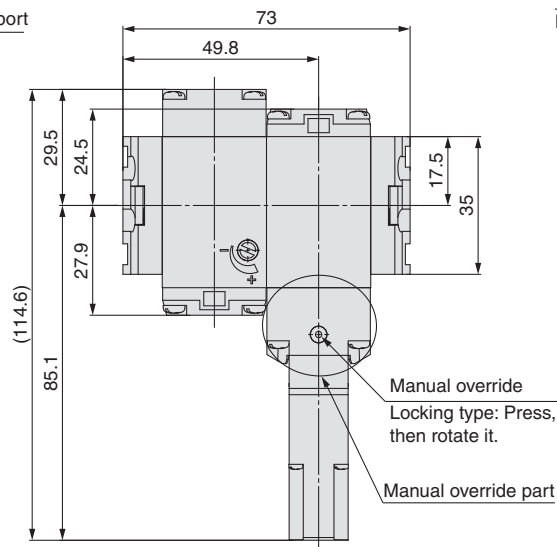
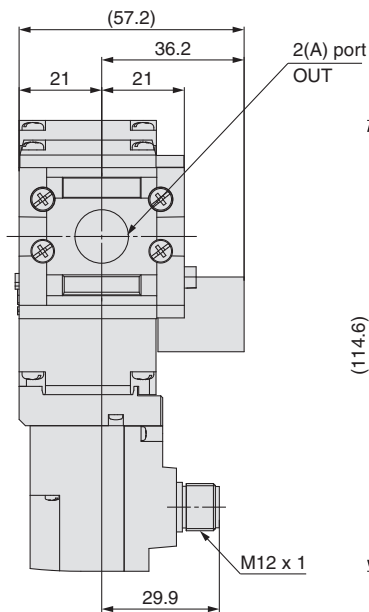
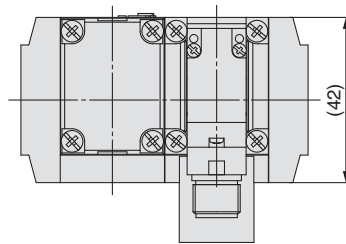
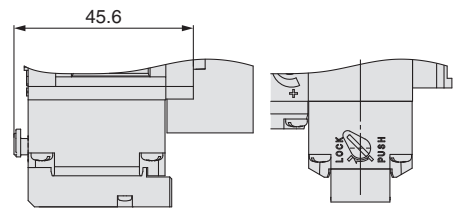

Dimensions

N.C. (Normally closed)
VP546E-X660

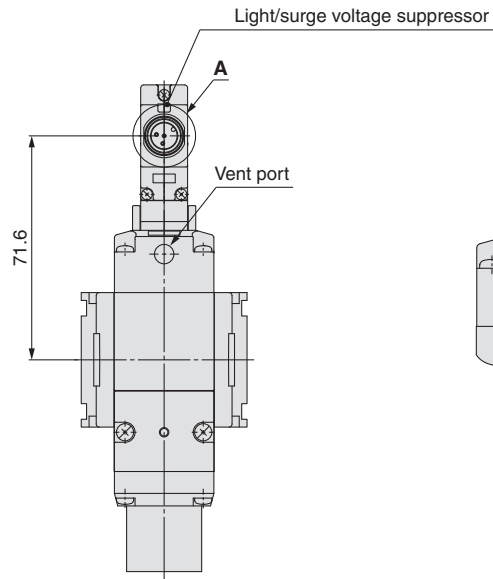

Details of manual override part
(for manual operation)

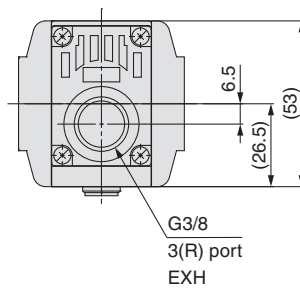
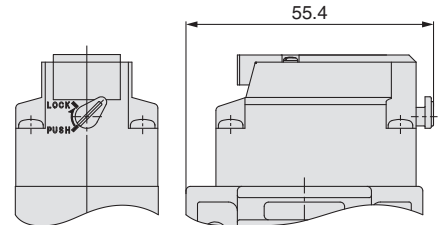

Detailed figure of A section
M12 connector

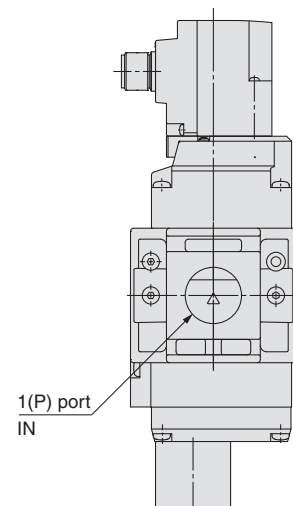
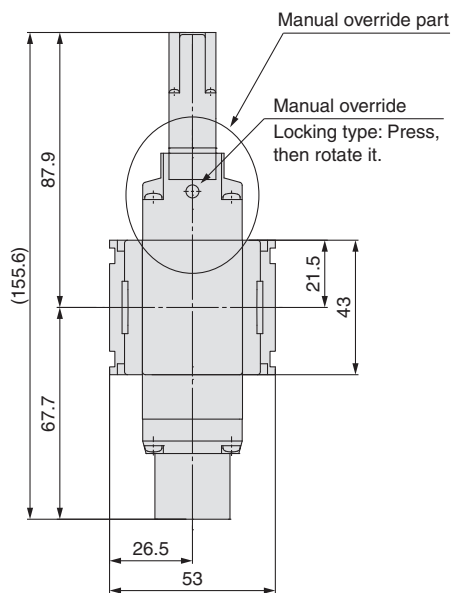
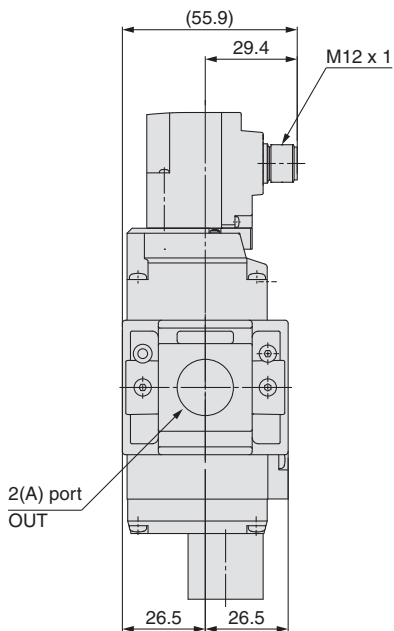
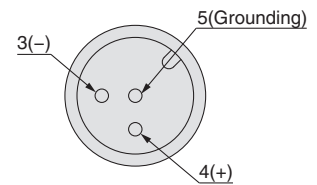

VP346E/546E/746E/946E-X660/X661

Dimensions

N.O. (Normally open)
VP546E-X661

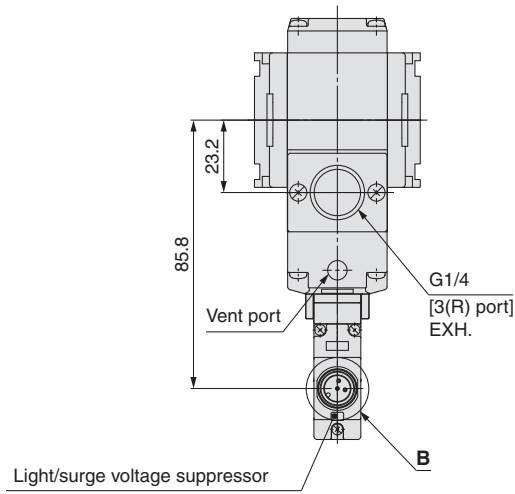

Details of manual override part
(for manual operation)

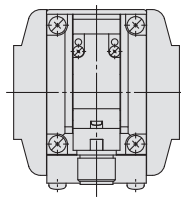
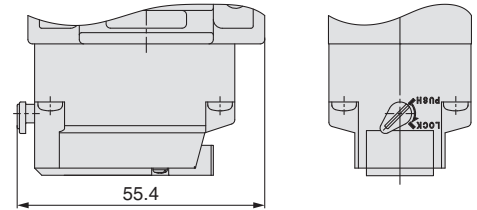

Detailed figure of B section
M12 connector

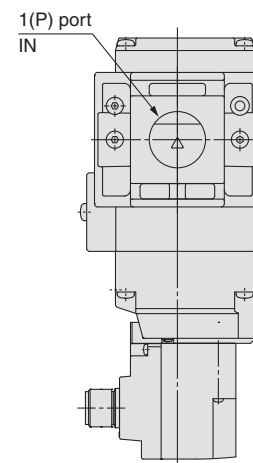
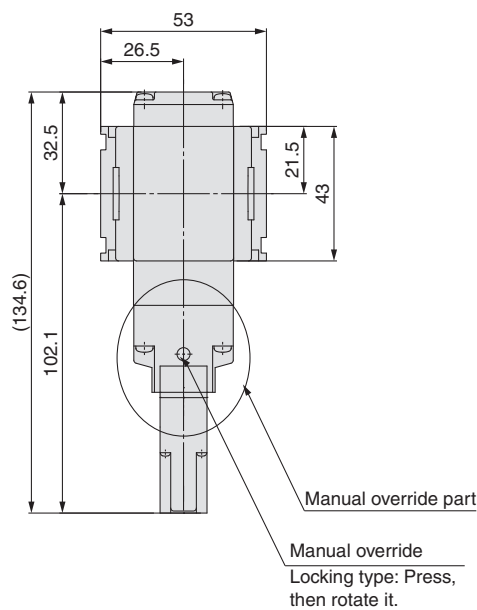
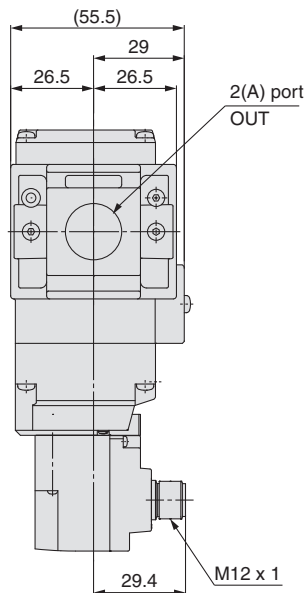
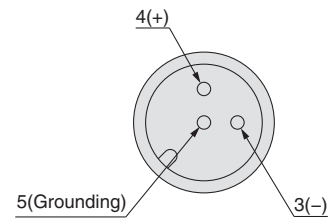

Dimensions

With soft start-up function
N.C. (Normally closed)
VP546E-S-X660

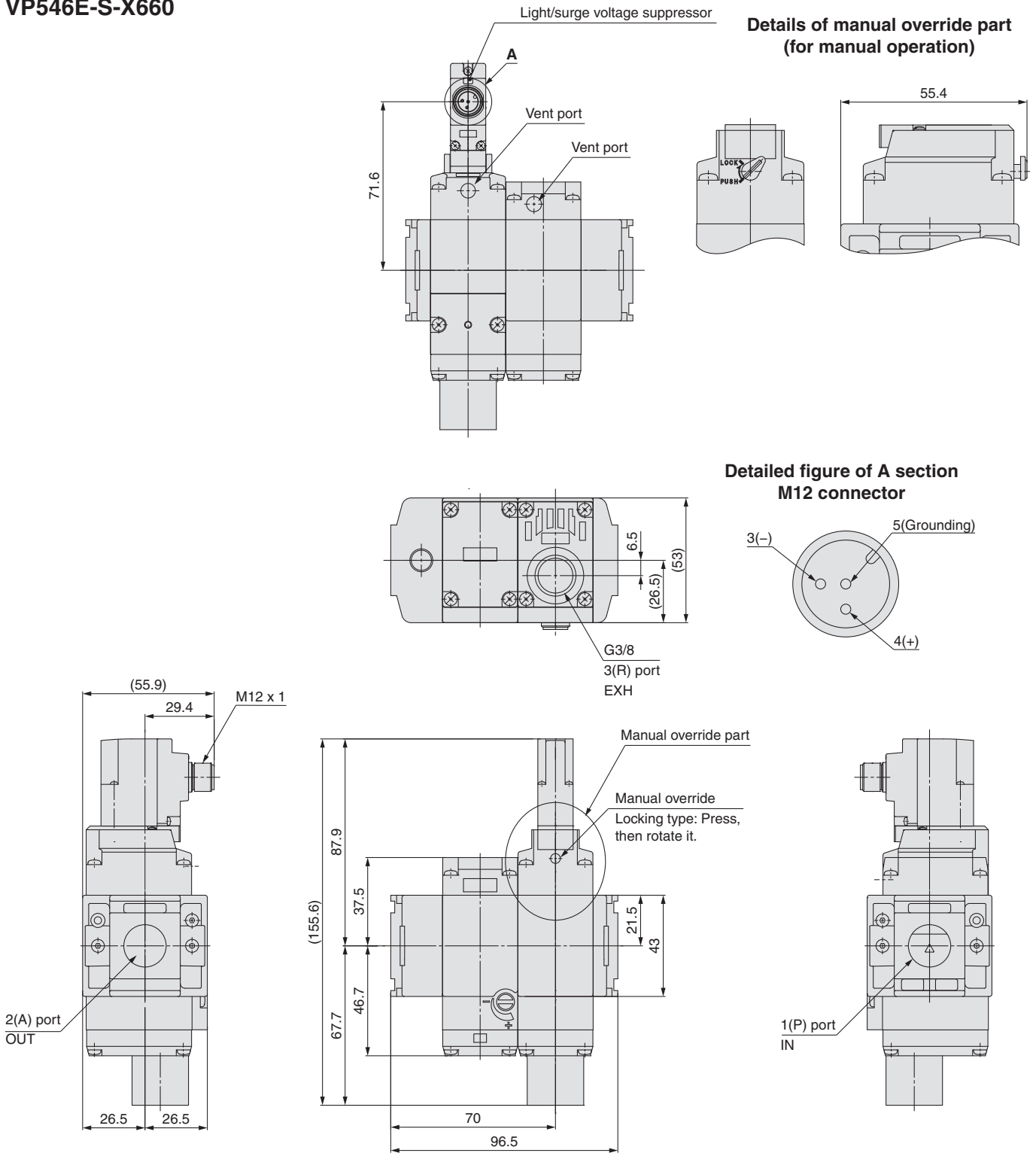

VP346E/546E/746E/946E-X660/X661

Dimensions

With soft start-up function
 N.O. (Normally open)
 VP546E-S-X661

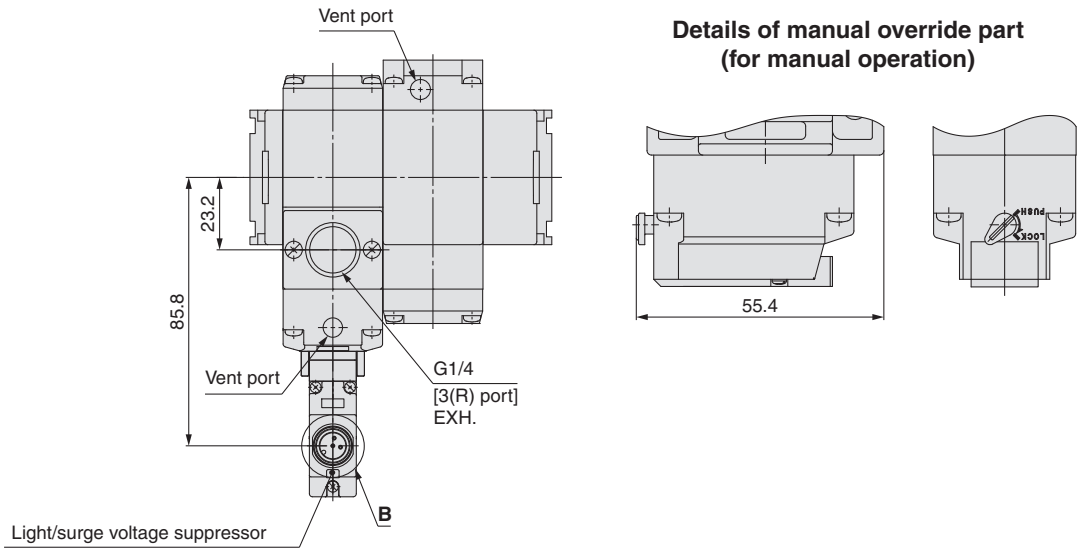

Detailed figure of B section
 M12 connector

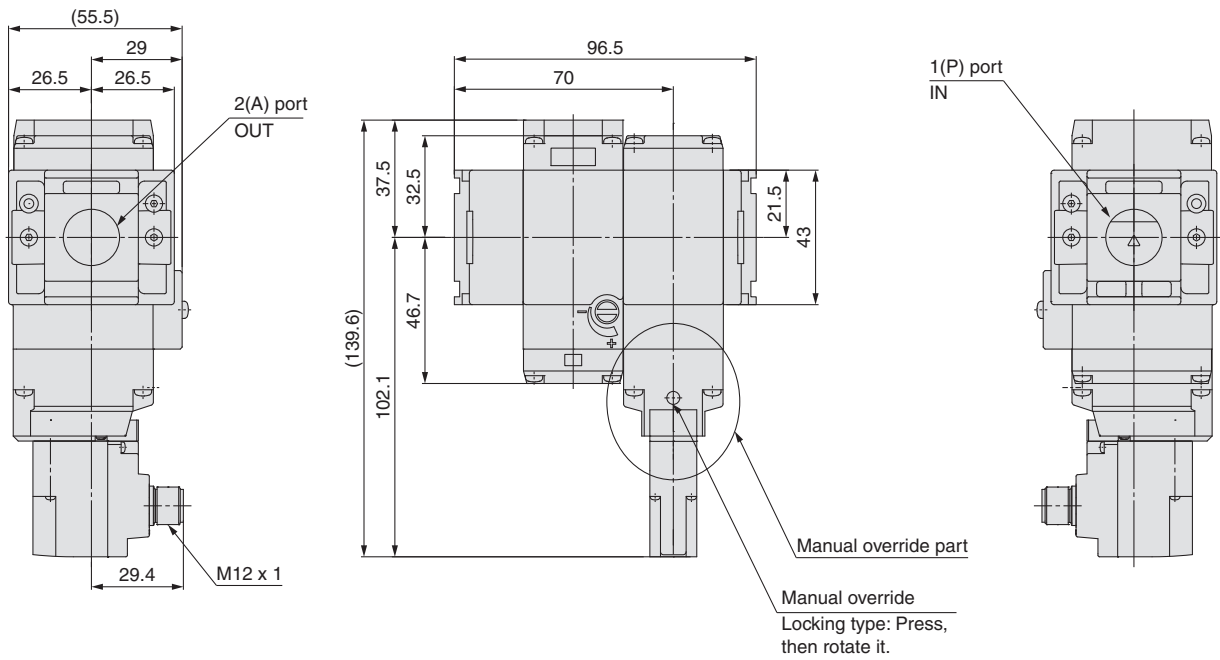
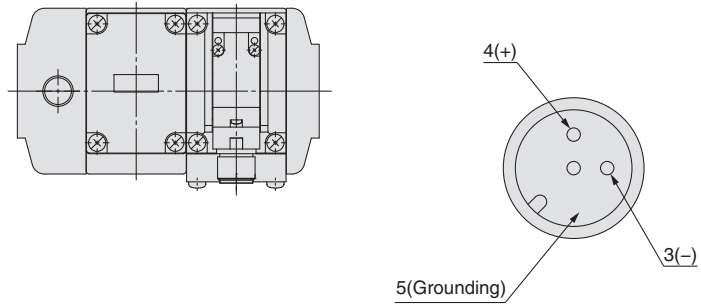

Dimensions

**N.C. (Normally closed)
VP746E-X660**

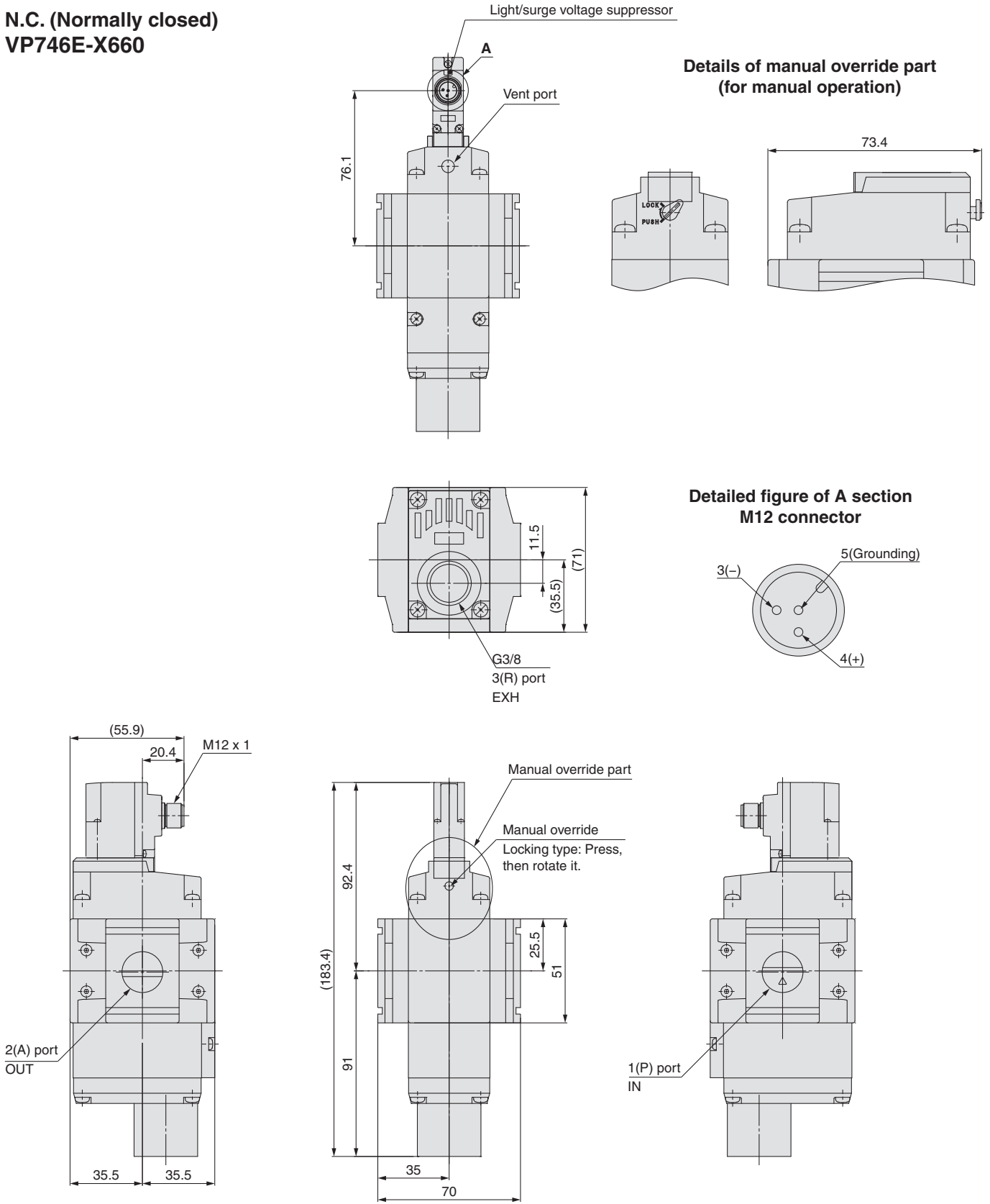

VP346E/546E/746E/946E-X660/X661

Dimensions

N.O. (Normally open)
VP746E-X661

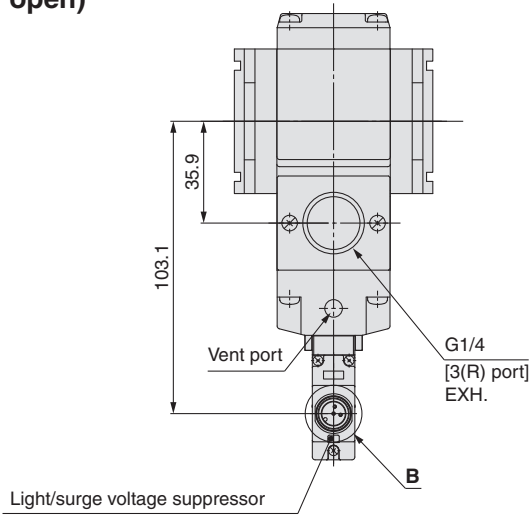

Details of manual override part
(for manual operation)

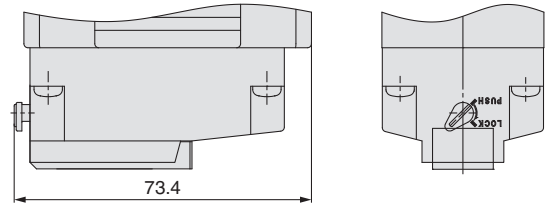

Detailed figure of B section
M12 connector

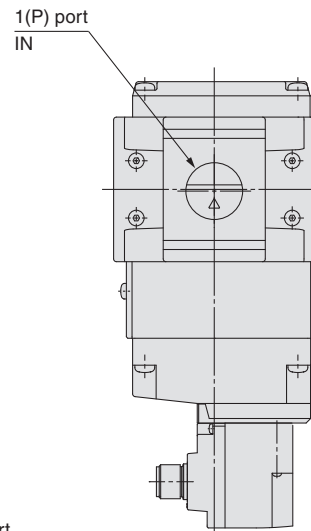
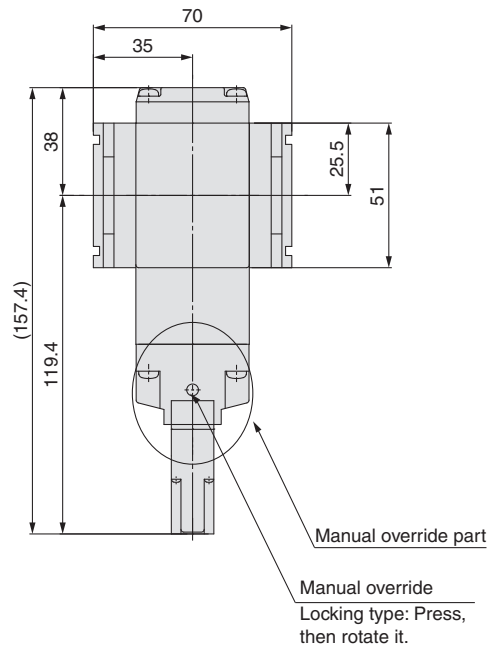
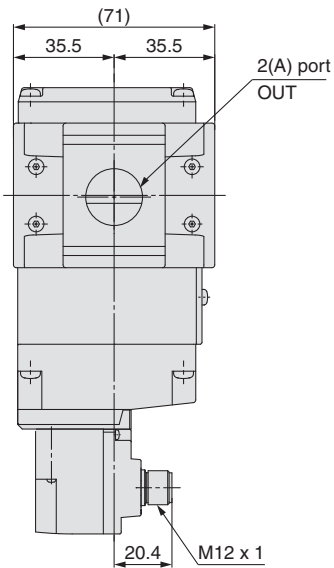
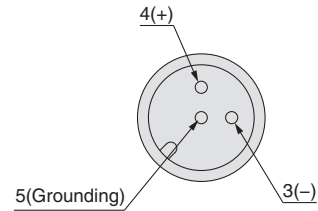
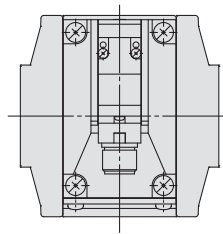

Dimensions

With soft start-up function
N.C. (Normally closed)
VP746E-S-X660

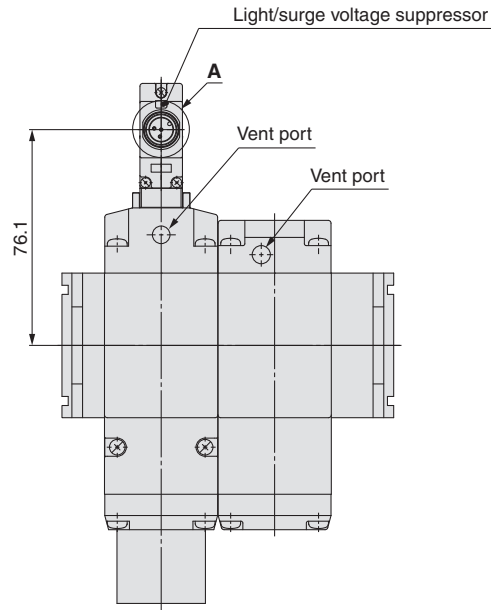

Details of manual override part
(for manual operation)

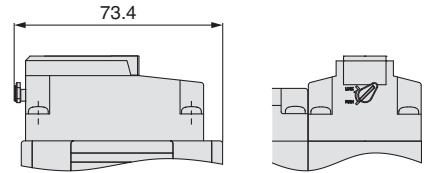

Detailed figure of A section
M12 connector

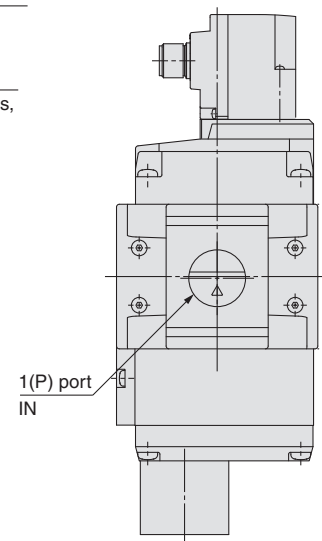
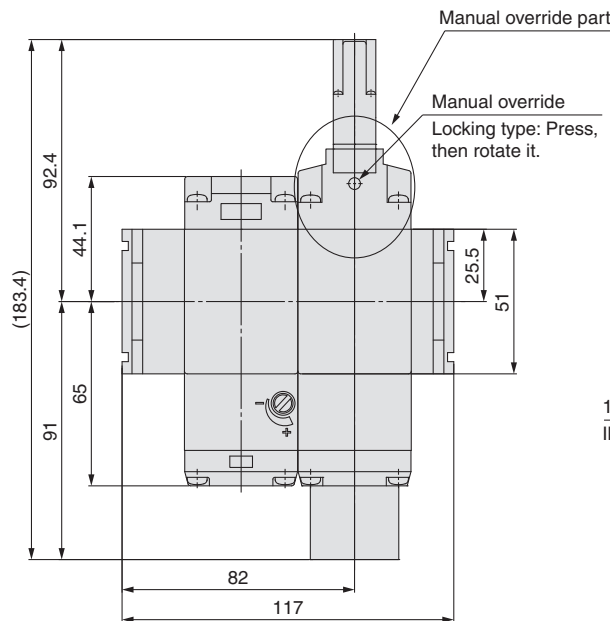
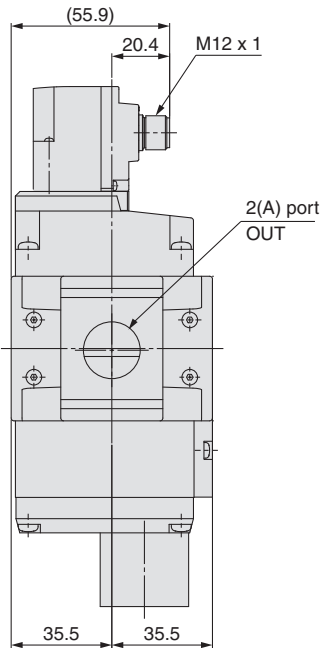
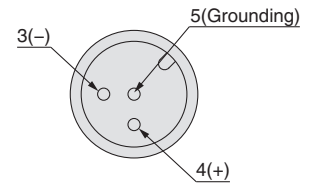
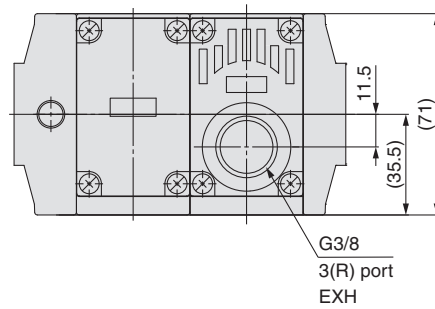

VP346E/546E/746E/946E-X660/X661

Dimensions

With soft start-up function
 N.O. (Normally open)
 VP746E-S-X661

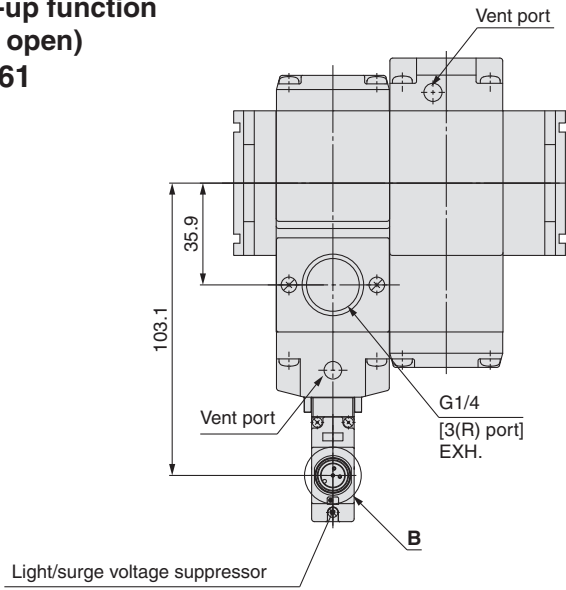

Details of manual override part
 (for manual operation)

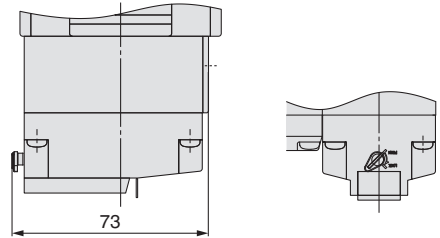

Detailed figure of B section
 M12 connector

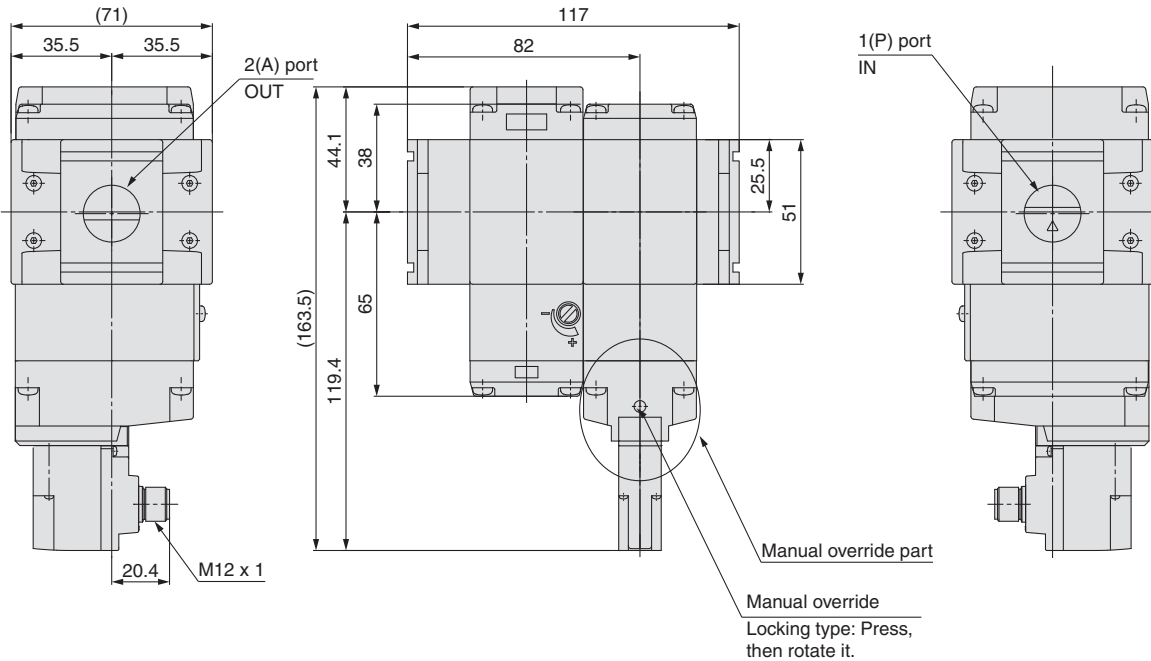
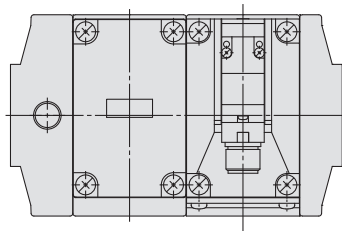
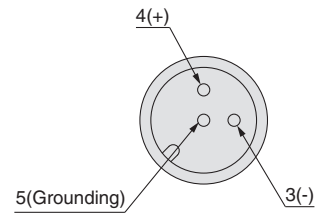

Dimensions

N.C. (Normally closed)

VP946E-X660

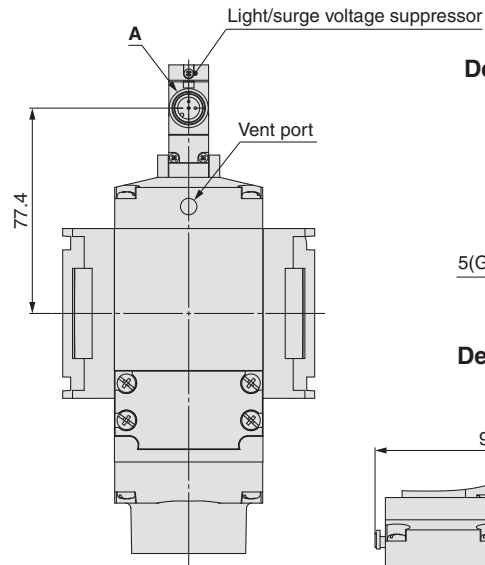

Detailed figure of A section
M12 connector

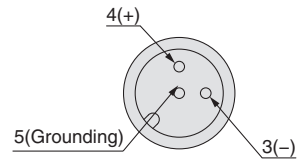

Details of manual override part
(for manual operation)
Type E

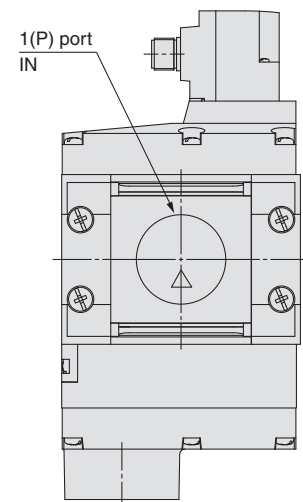
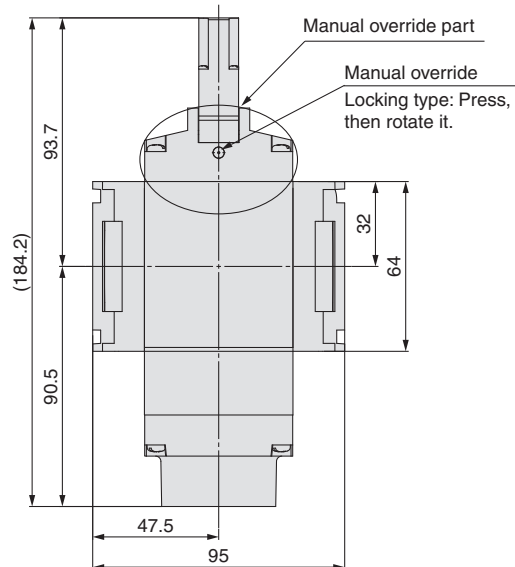
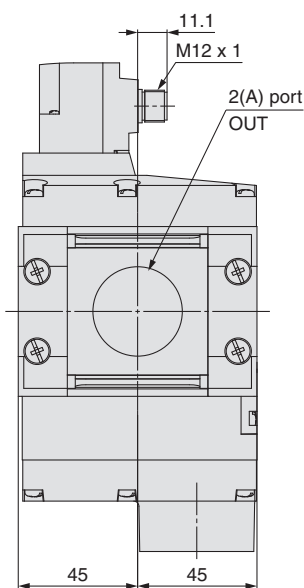
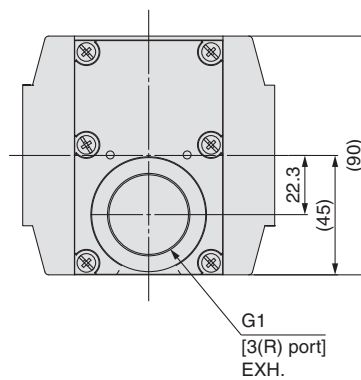
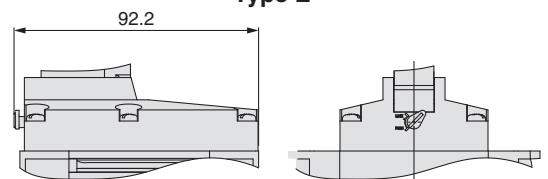

VP346E/546E/746E/946E-X660/X661

Dimensions

N.O. (Normally open)
VP946E-X661

Detailed figure of A section
M12 connector

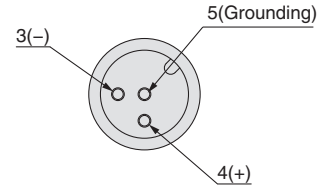

Details of manual override part
(for manual operation)
Type E

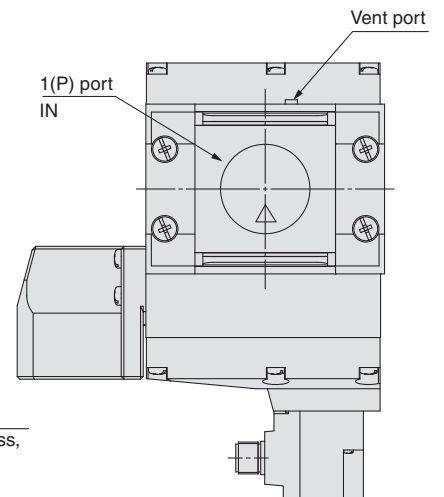
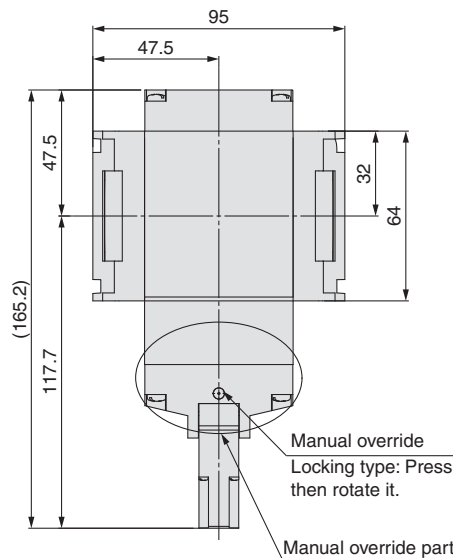
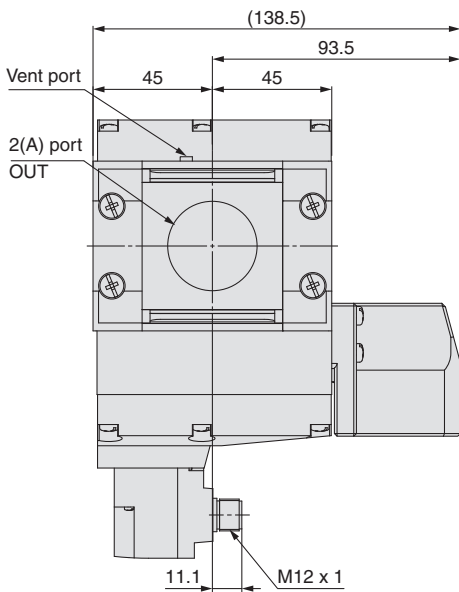
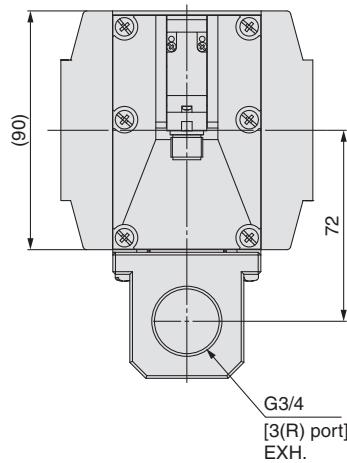
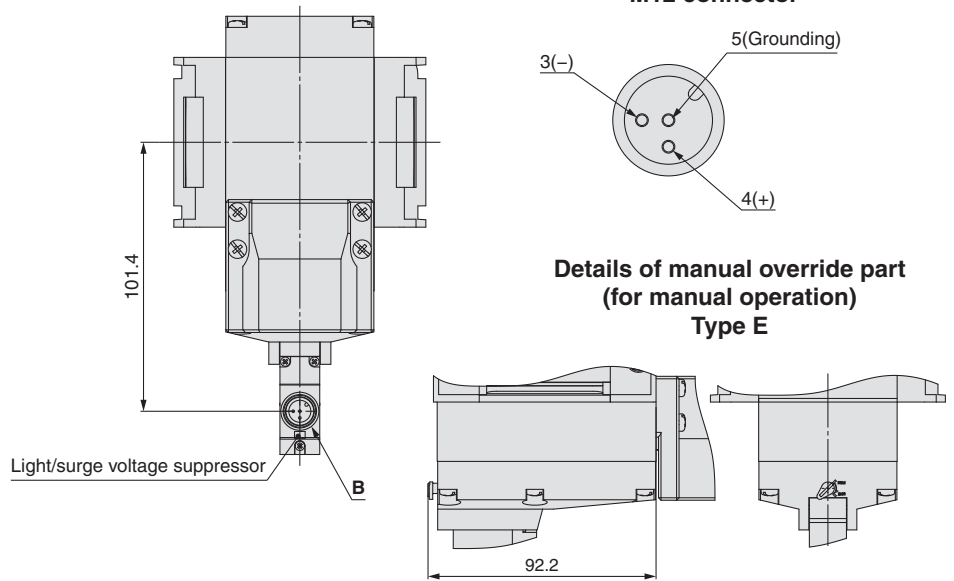

Dimensions

With soft start-up function
N.C. (Normally closed)
VP946E-S-X660

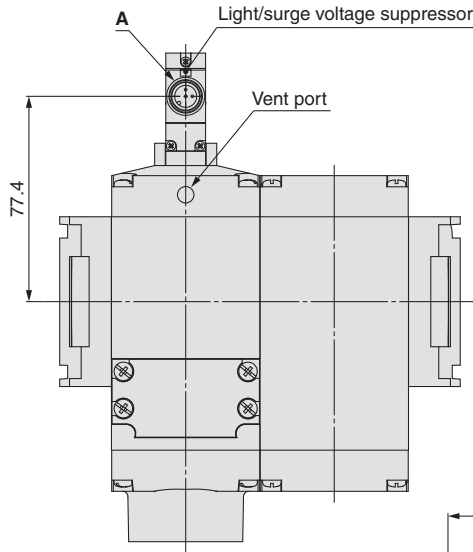

Detailed figure of A section
M12 connector

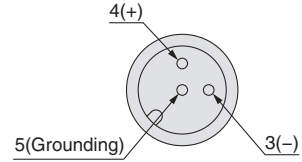

Details of manual override part
(for manual operation)
Type E

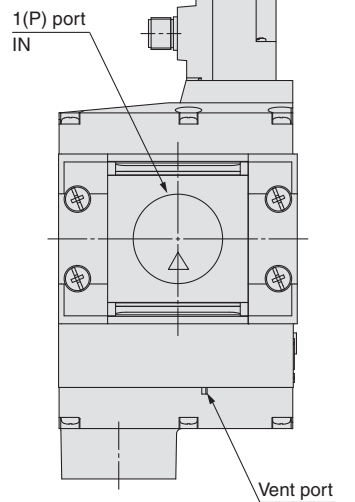
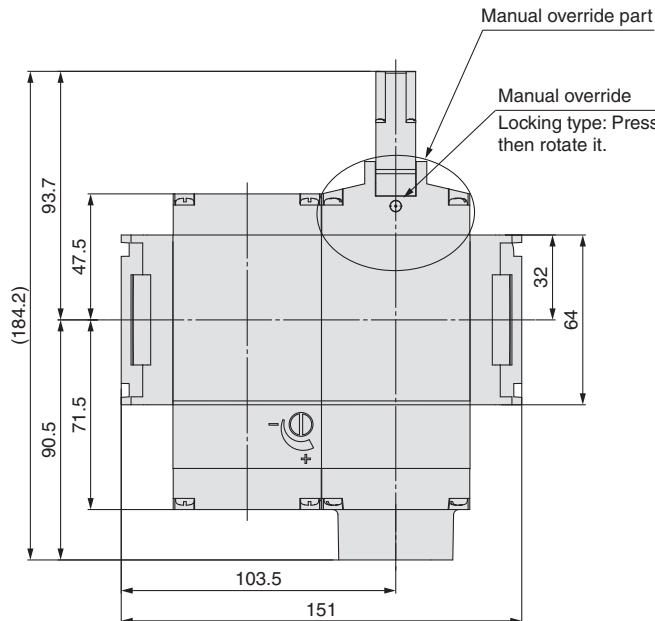
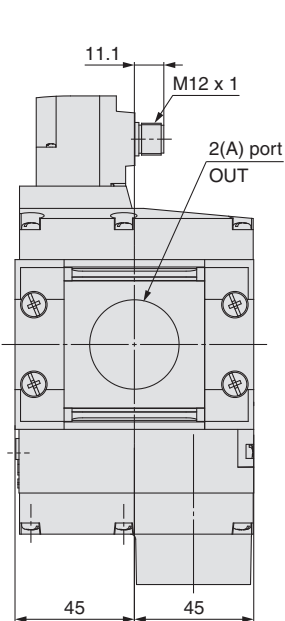
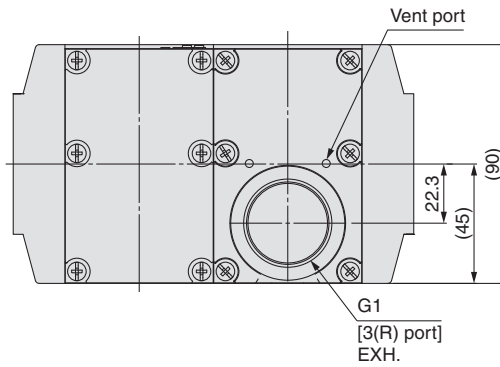
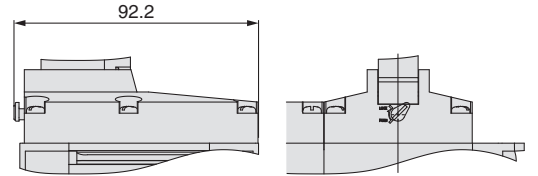

VP346E/546E/746E/946E-X660/X661

Dimensions

With soft start-up function
 N.O. (Normally open)
 VP946E-S-X661

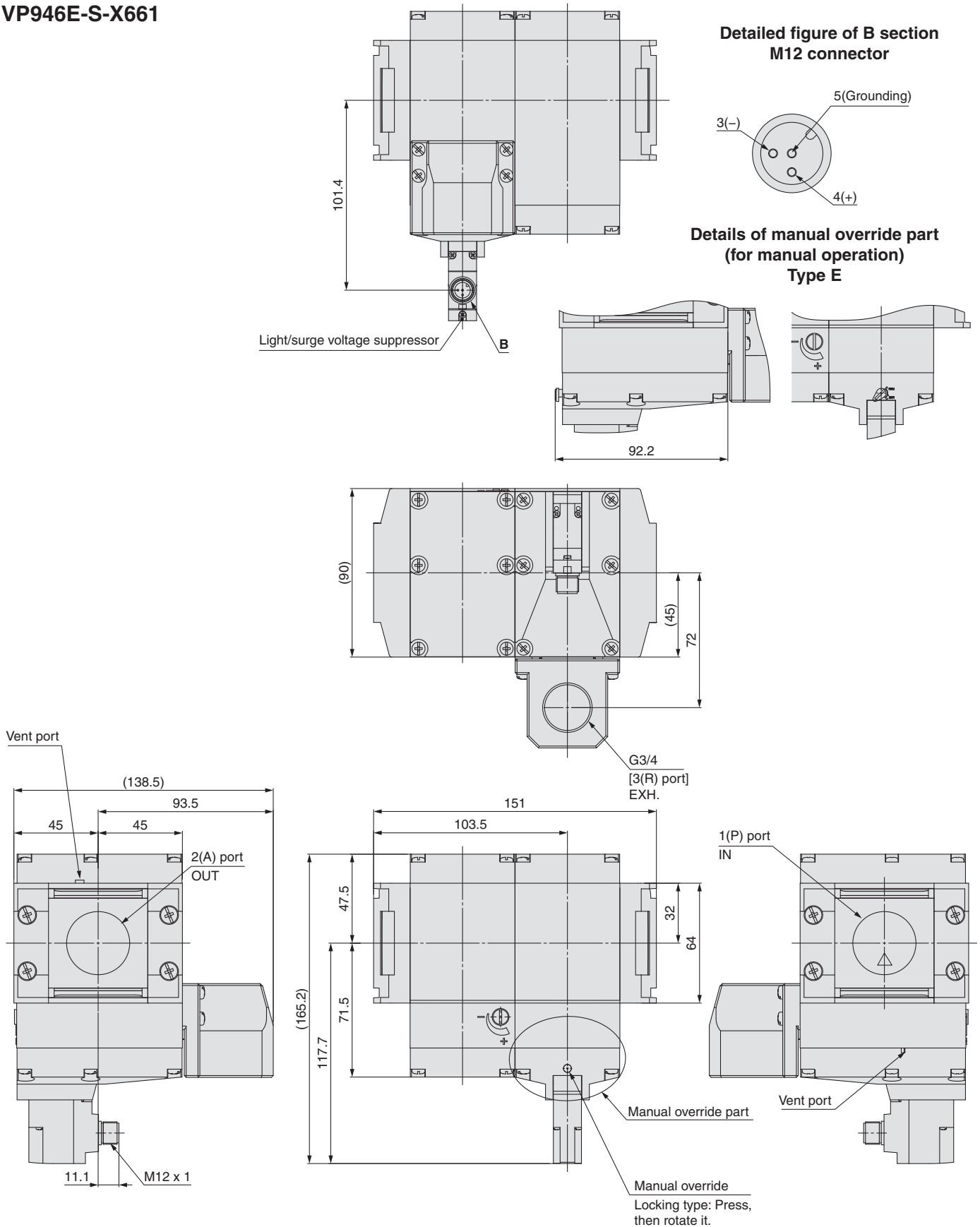

AMS20/30/40/60 Series Accessories

List of Accessories

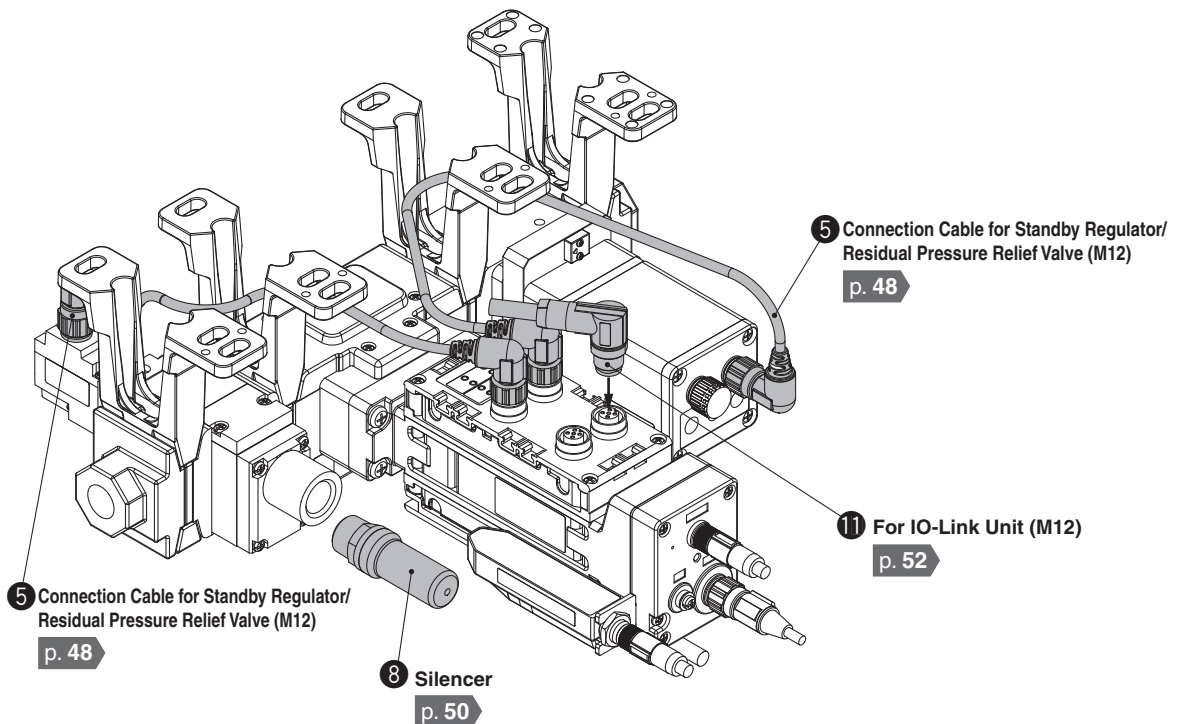
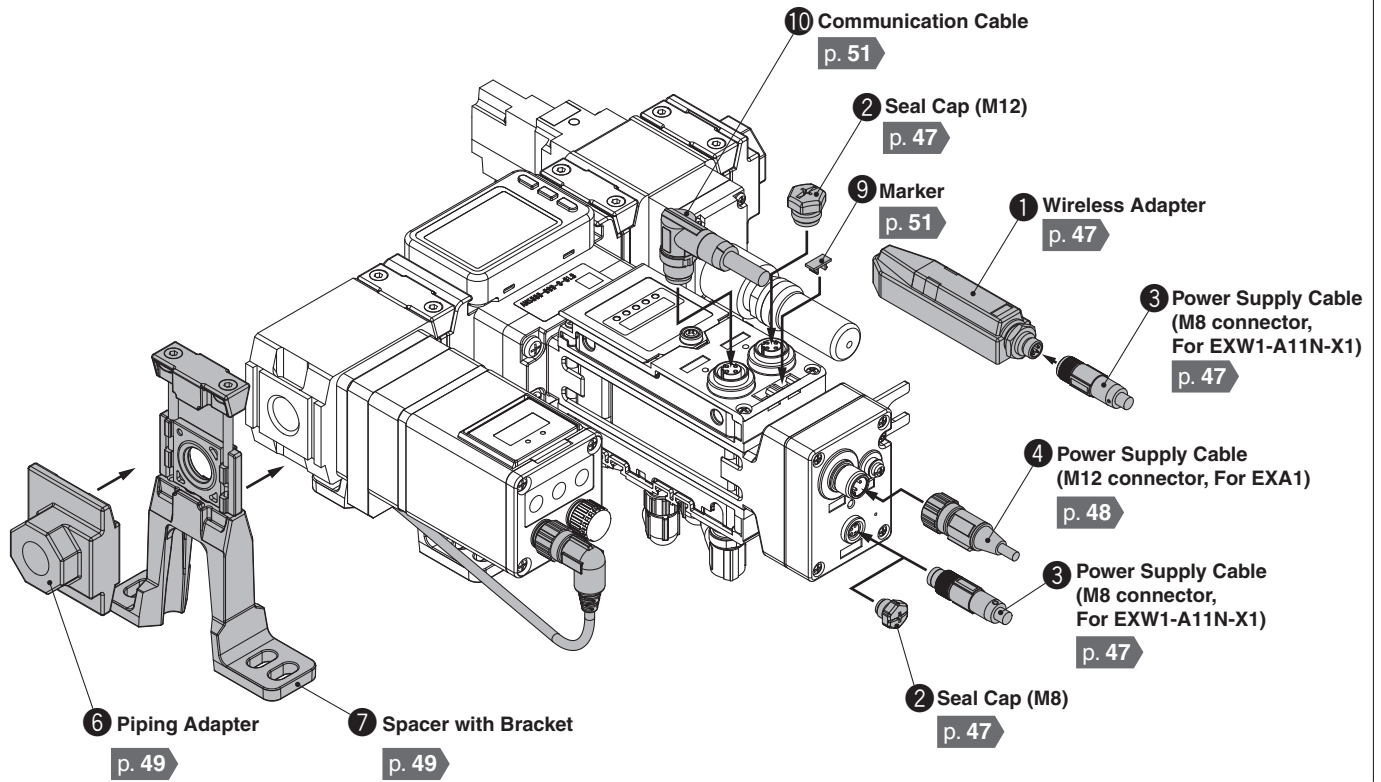

AMS20/30/40/60 Series

① Wireless Adapter

Wireless adapter for air management hub EXA1

EXW1-A11N-X1

Specifications

Item	Specifications	
Wireless communication	Protocol	SMC original protocol (SMC encryption)
	Radio wave type (spread)	Frequency Hopping Spread Spectrum (FHSS)
	Frequency	2.4 GHz (2403 to 2481 MHz)
	Number of frequency channels	79 ch
	Channel bandwidth	1.0 MHz
	Communication speed	1 Mbps
	Communication distance	Approx. 100 m (Depending on the operating environment)
	Radio Law certificate	Refer to the SMC website for the latest information regarding in which countries the product is certified.
Electrical	Power supply voltage range	24 VDC +10 % to 12 VDC -10 %
	Current consumption	50 mA or less
General	Enclosure	IP67
	Ambient temperature (Operating temperature)	0 to 50 °C
	Ambient temperature (Storage temperature)	-10 to 60 °C
	Ambient humidity	35 to 85 %RH (No condensation)
	Withstand voltage	500 VAC, 1 min
	Insulation resistance	500 VDC, 10 MΩ or more
	Vibration resistance	Conforms to EN 61131-2 5 <= f < 8.4 Hz 3.5 mm 8.4 <= f < 150 Hz 9.8 m/s ²
	Impact resistance	Conforms to EN 61131-2 147 m/s ² , 11 ms
	Standards	CE/UKCA marking
	Weight	40 g

Please purchase an EXW1-AC-X1 connection cable separately.

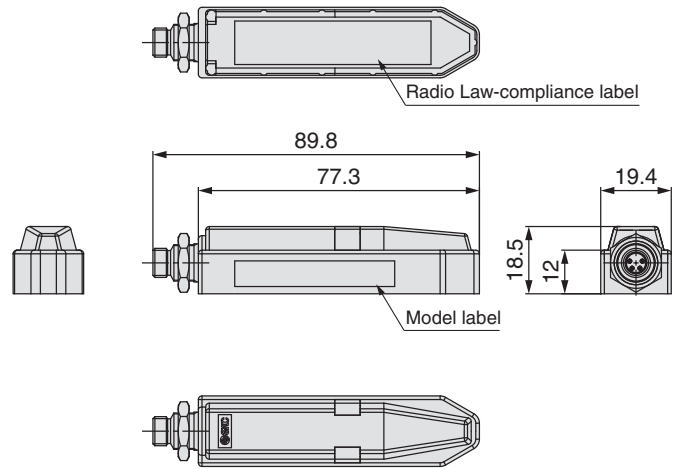

Connector

M8, 4-pin, plug	Terminal no.	Description
	1	24V (US1)
	2	Internal bus B
	3	0V (US1)
	4	Internal bus A

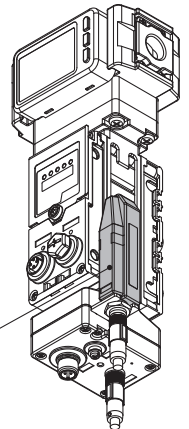

Wireless adapter

* Included parts: Fixing bracket

② Seal Cap (10 pcs.)

Be sure to mount a seal cap on any unused I/O connectors.

Otherwise, the specified enclosure cannot be maintained.

EX9-AWES

For M8



EX9-AWTS

For M12



③ Power Supply Cable (M8 connector, For EXW1-A11N-X1, With connectors on both sides (socket/plug))

EXW1-AC1-X1 Straight 0.3 m

* This product must be used in a fixed position.

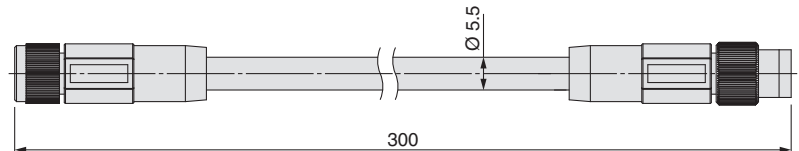

Socket connector pin arrangement

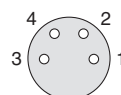

Terminal no.

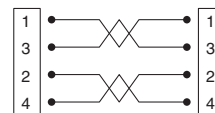

Connections

Terminal no.

Plug connector pin arrangement

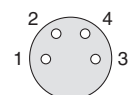

Item	Specifications
Cable O.D.	Ø 5.5 mm
Conductor nominal cross section	AWG24
Wire O.D. (Including insulator)	1.12 mm
Min. bending radius	22 mm

④ Power Supply Cable (M12 connector, For EXA1)

* The shape of the M12 connector is A-coded (Normal key).

EX500-AP **050** - **S**

Cable length (L)

010	1000 mm
050	5000 mm

Connector specification

S	Straight
A	Angled



Straight connector type

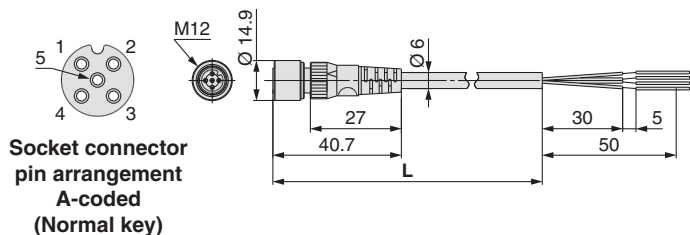

Item	Specifications
Cable O.D.	Ø 6 mm
Nominal cross section	0.3 mm ² /AWG22
Wire diameter (Including insulator)	1.5 mm
Min. bending radius	40 mm (Fixed)

Angled connector type

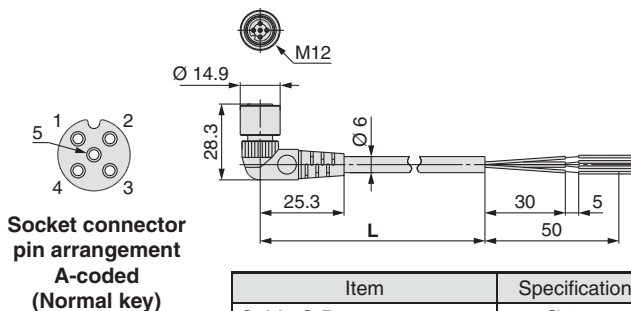

Item	Specifications
Cable O.D.	Ø 6 mm
Nominal cross section	0.3 mm ² /AWG22
Wire diameter (Including insulator)	1.5 mm
Min. bending radius	40 mm (Fixed)

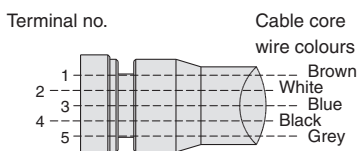

Connections

ZS-37-A

Lead wire with M12 connector

Pin no.	Pin name	Wire colour
1	DC(+)	Brown
2	N.C.	White
3	DC(-)	Blue
4	N.C.	Black

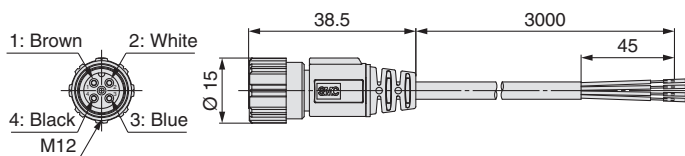

Cable Specifications

Item	Specifications
Conductor	Nominal cross section AWG23
Insulator	Outside diameter Approx. 1.1 mm
	Colour Brown, Blue, Black, White
Sheath	Finished outside diameter Ø 4

⑤ Connection Cable for Standby Regulator/Residual Pressure Relief Valve (With M12 angle connectors on both sides (male/female))

EXA1-AC1 Cable length L: 320 mm

EXA1-AC2 Cable length L: 220 mm

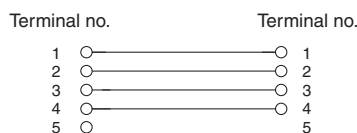
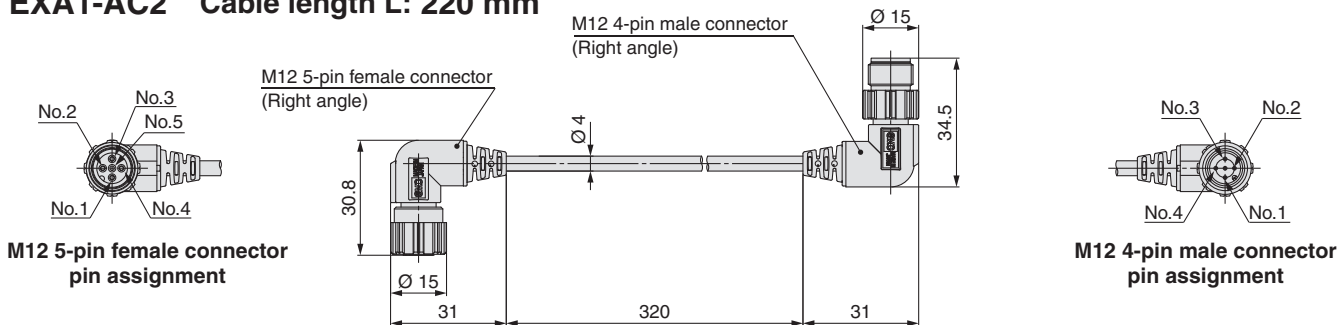

Connections

Component and Connection Cable Suitable Table

Body size	Standby electro-pneumatic regulator	Standby regulator	Residual pressure relief valve
20			
30	EXA1-AC1	EXA1-AC2	EXA1-AC2
40			EXA1-AC1
60			

AMS20/30/40/60 Series

6 Piping Adapter

A piping adapter allows for the installation/removal of the component without removing the piping and thus makes maintenance easier.

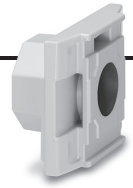

E 200 - □ 01 -D

Applicable size

200	AMS20
300	AMS30
400	AMS40
600	AMS60

Thread type

Symbol	Thread type
—	Rc
F	G
N	NPT

Port size

Symbol	Port size	AMS20	AMS30	AMS40	AMS60
01	1/8	●			
02	1/4	●	●		
03	3/8		●	●	
04	1/2			●	
06	3/4				●
10	1				●

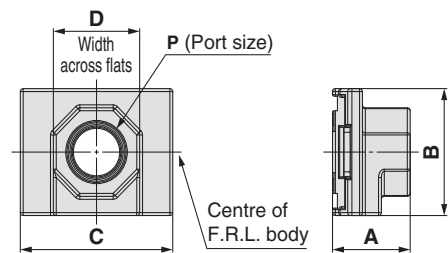

Model	P	A	B	C	D
E200-□01-D	1/8	24	35	42	24
E200-□02-D	1/4	24	35	42	24
E300-□02-D	1/4	27	43	53	30
E300-□03-D	3/8	27	43	53	30
E400-□03-D	3/8	30	51	71	36
E400-□04-D	1/2	30	51	71	36
E600-□06-D	3/4	39	64	90	46
E600-□10-D	1	39	64	90	46

* A spacer with bracket is required for modular unit.

7 Spacer with Bracket

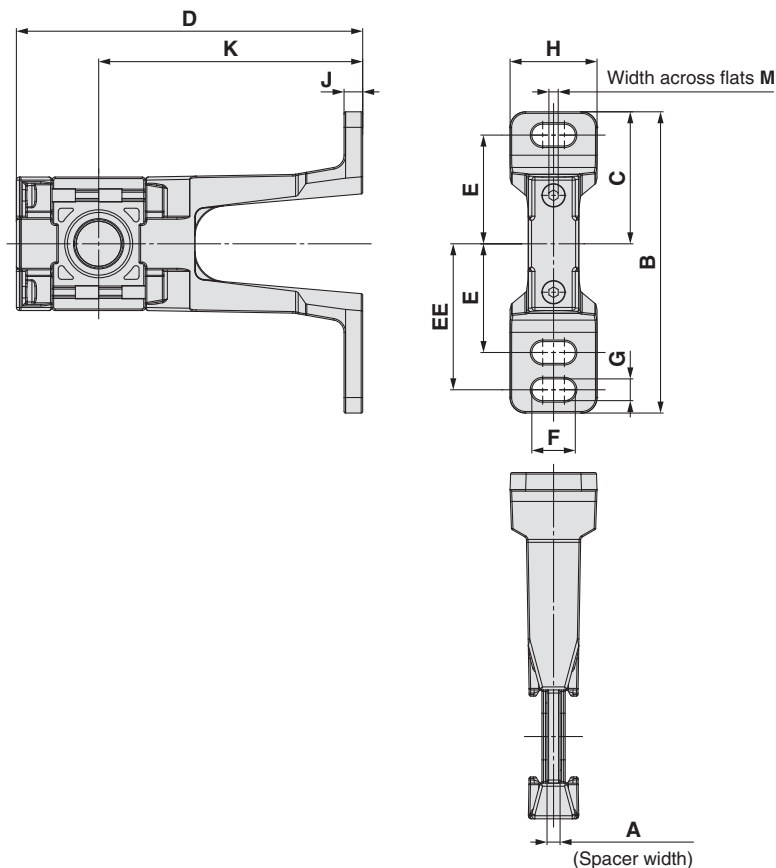

Model	A	B	C	D	E	EE	F	G	H	J	K	M	Applicable size
Y200T-2-D	3.2	97	42.5	106	35	47	14	7	28	6	85	2	AMS20
Y300T-2-D	4.2	97	42.5	111.5	35	47	14	7	28	6	85	3	AMS30
Y400T-1-D	5.2	115	50	120.5	40	55	18	9	32	7	85	3	AMS40
Y600T-2-D	6.2	140	60	145	50	70	20	11	37	8	100	4	AMS60

8 Silencer

Compact Resin Type

AN20 AN30, AN40

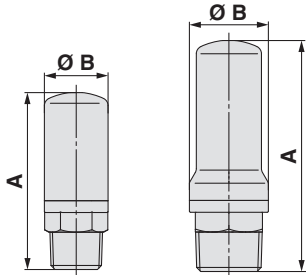

Dimensions [mm]

Model	Port size R	A	B
AN20-02	1/4	45	16.5
AN30-03	3/8	58.5	20
AN40-04	1/2	68	24

Metal Body Type

AN500, 600

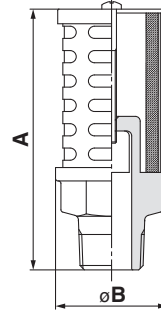

Dimensions [mm]

Model	Port size R	A	B
AN500-06	3/4	107	46
AN600-10	1	127	50

High Noise Reduction Type

AN202 to 402



Dimensions [mm]

Model	Port size R	A	B
AN202-02	1/4	64	22
AN302-03	3/8	84	28
AN402-04	1/2	95	34

High Noise Reduction Type

ANA1-06 ANA1-10

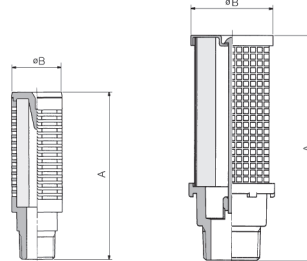

Dimensions [mm]

Model	Port size R	A	B
ANA1-06	3/4	111	46
ANA1-10	1	132	50

Compatibility Chart for Residual Pressure Relief Valve and Silencers

	Silencer	Compact resin type			Metal type		High noise reduction type					
		Model	AN20-02	AN30-03	AN40-04	AN500-06	AN600-10	AN202-02	AN302-03	AN402-04	ANA1-06	ANA1-10
		Port size	1/4	3/8	1/2	3/4	1	1/4	3/8	1/2	3/4	1
VP346E	X660 (N.C.)	○	—	—	—	—	○	—	—	—	—	
	X661 (N.O.)	○	—	—	—	—	—	—	—	—	—	
VP546E	X660 (N.C.)	—	○	—	—	—	—	○	—	—	—	
	X661 (N.O.)	—	○	—	—	—	—	—	—	—	—	
VP746E	X660 (N.C.)	—	—	○	—	—	—	—	○	—	—	
	X661 (N.O.)	—	○	—	—	—	—	—	—	—	—	
VP946E	X660 (N.C.)	—	—	—	—	○	—	—	—	—	○	
	X661 (N.O.)	—	—	—	○	—	—	—	—	○	—	

AMS20/30/40/60 Series

9 Marker (1 sheet, 88 pcs.)

The signal name of I/O device and each unit address can be entered and mounted on each unit.

EX600-ZT1

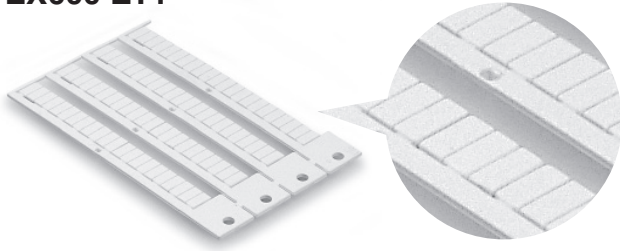

10 Communication Cable

For EtherCAT® For PROFINET For EtherNet/IP™

EX9-AC 005 EN-PSPS (With connector on both sides (Plug/Plug))

Cable length (L)

005	500 mm
010	1000 mm
020	2000 mm
030	3000 mm
050	5000 mm
100	10000 mm

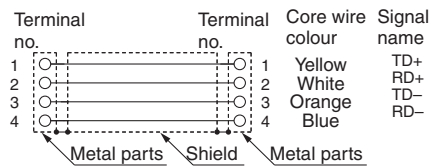
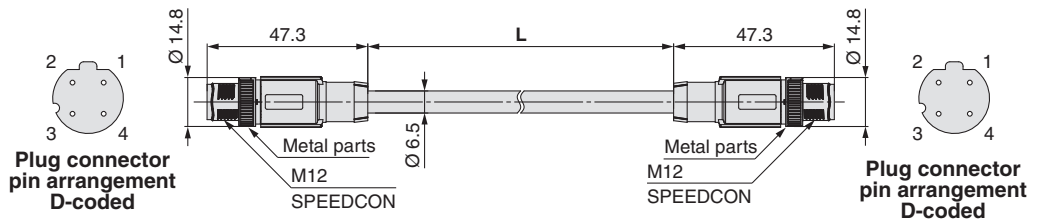

Item	Specifications
Cable O.D.	Ø 6.5 mm
Conductor nominal cross section	0.34 mm ² /AWG22
Wire O.D. (Including insulator)	1.55 mm
Min. bending radius (Fixed)	19.5 mm

Connections (Straight cable)

EX9-AC 005 EN-PAPA (With angled connector on both sides (Plug/Plug))

Cable length (L)

005	500 mm
010	1000 mm
020	2000 mm
030	3000 mm
050	5000 mm
100	10000 mm

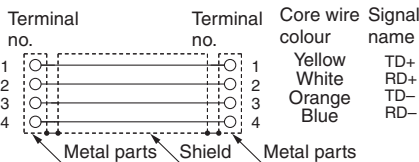
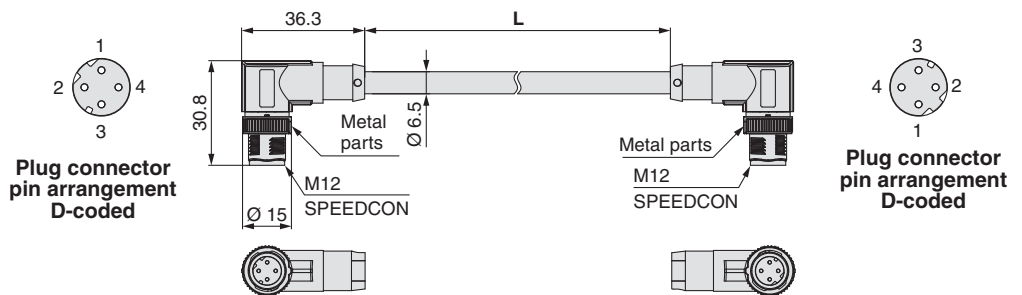

Item	Specifications
Cable O.D.	Ø 6.5 mm
Conductor nominal cross section	0.34 mm ² /AWG22
Wire O.D. (Including insulator)	1.55 mm
Min. bending radius (Fixed)	19.5 mm

Connections (Straight cable)

① Cable with Connector for IO-Link Unit

EX9-AC 005 -SSPS (With connector on both sides (Socket/Plug))

● Cable length (L)

005	500 mm
010	1000 mm
020	2000 mm
030	3000 mm
050	5000 mm
100	10000 mm

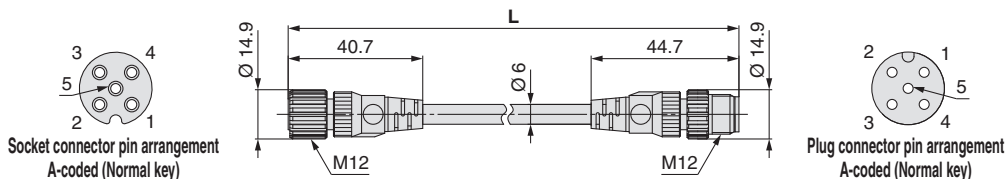

Terminal no.	Wire guide colour
1	Brown
2	White
3	Blue
4	Black
5	Grey

Connections

Item	Specifications
Cable O.D.	Ø 6 mm
Conductor nominal cross section	0.3 mm ² /AWG22
Wire O.D. (Including conductor)	1.5 mm
Min. bending radius (Fixed)	40 mm

② I/O Cable with Connector, I/O Connector

Name	Use	Part no.	Description
Cable with connector	For sensor	PCA-1557769	Cable with M12 connector (4 pins/3 m)
		PCA-1557772	Cable with M8 connector (3 pins/3 m)
Field-wireable connector	For sensor	PCA-1557730	Field-wireable connector (M8/3 pins/Plug/Piercecon® connection)
		PCA-1557743	Field-wireable connector
		PCA-1557756	(M12/4 pins/Plug/QUICKON-ONE connection/SPEEDCON)
Y connector	For sensor	PCA-1557785	Y connector (2 x M12 (5 pins)-M12 (5 pins)/SPEEDCON)
		PCA-1557798	Y connector (2 x M8 (3 pins)-M12 (4 pins)/SPEEDCON)

* When using the Y connector, connect it to the connector on the I/O unit through the sensor cable (PCA-1557769) with the M12 connector.

③ IO-Link Device Tool License Key

**USB dongle
EX9-ZSW-LDT1**

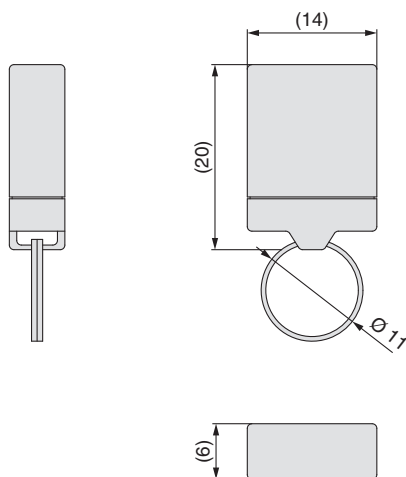



AMS20/30/40/60 Series Specific Product Precautions 1

Be sure to read this before handling the products. Refer to the back cover for safety instructions. For common precautions, refer to the "Operation Manual" on the SMC website: <https://www.smc.eu>

Design / Selection

Warning

1. Confirm the specifications.

Products represented in this catalog are designed only for use in compressed air systems.

Do not operate at flow rates, pressures, temperatures, etc., beyond the range of specifications, as this can cause damage or malfunction. (Refer to the specifications.)

Please contact SMC when using a fluid other than compressed air. We do not guarantee against any damage if the product is used outside of the specification range.

2. Do not disassemble the product or make any modifications, including additional machining.

Doing so may cause human injury and/or an accident.

Caution

1. Do not install in places where it can be used as a foothold.

Applying any excessive load such as stepping on the product by mistake or placing a foot on it will cause it to break.

2. If excessive carbon dust is generated by the compressor, it may adhere to the inside of this product and cause it to malfunction.

3. Slight scratches or dirt on the display or the product body will not cause any problems. Please continue to use the product.

Mounting

Warning

1. Operation manual

Install the products and operate them only after reading the operation manual carefully and understanding its contents. Also, keep the manual where it can be referred to as necessary.

2. Ensure sufficient space for maintenance activities.

When installing the products, allow access for maintenance and inspection.

3. Tighten threads with the proper tightening torque.

When installing the products, follow the listed torque specifications.

4. If air leakage increases or equipment does not operate normally, stop operation.

Check mounting conditions when air and power supplies are connected. Initial function and leakage tests should be performed after installation.

Caution

1. Do not use a lubricator on the supply side of this product, as doing so may result in a malfunction. When lubrication of terminal equipment is necessary, connect a lubricator on the output side of this equipment.

Piping

Warning

1. To screw piping material into a component, tighten with the recommended tightening torque while holding the female thread side.

If the tightening torque is insufficient, looseness or seal failure may occur. On the other hand, excess tightening torque can cause damage to the threads. Furthermore, tightening without holding the female thread side can cause damage due to the excess force that is applied directly to the piping bracket.

Recommended Tightening Torque

Unit: N·m

Connection thread	1/8	1/4	3/8	1/2	3/4	1
Torque	3 to 5	8 to 12	15 to 20	20 to 25	28 to 30	36 to 38

2. Avoid excessive torsional moment or bending moment other than those caused by the equipment's own weight, as this can cause damage.

Support external piping separately.

3. Piping materials without flexibility, such as steel tube piping, are prone to be affected by excess moment loads and vibrations from the piping side. Use flexible tubing in between to avoid such effects.

Caution

1. Preparation before piping

Before piping is connected, it should be thoroughly blown out with air (flushing) or washed to remove chips, cutting oil, and other debris from inside the pipe.

2. Winding of sealant tape

When screwing piping or fittings into ports, ensure that chips from the pipe threads or sealing material do not enter the piping. Also, if sealant tape is used, leave 1.5 to 2 thread ridges exposed at the end of the threads.

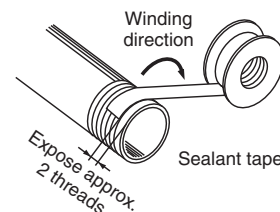



AMS20/30/40/60 Series

Specific Product Precautions 2

Be sure to read this before handling the products. Refer to the back cover for safety instructions. For common precautions, refer to the "Operation Manual" on the SMC website: <https://www.smc.eu>

Air Supply

Warning

1. Type of fluids

Please consult with SMC when using the product in applications other than compressed air.

2. Take measures to ensure air quality, such as by installing an aftercooler, air dryer, or water separator.

Compressed air that contains a large amount of drainage can result in the malfunction of this product and other pneumatic equipment. Therefore, take appropriate measures to ensure air quality, such as by providing an aftercooler, air dryer, or water separator.

For compressed air quality, refer to the Air Preparation Equipment Selection Guide (**Web Catalogue**).

3. Use clean compressed air.

Do not use compressed air that contains chemicals, synthetic oils that include organic solvents, salt, corrosive gases, etc., as it can cause damage or malfunction.

When synthetic oil is used for the compressor oil, depending on the type of synthetic oil used or on the conditions of use, there may be adverse effects on the resin of the pneumatic equipment or on the seals if the oil is flowed out to the outlet side. The mounting of a main line filter is recommended in such cases.

Caution

1. Ensure that the fluid and ambient temperatures are within the specified range.

When using at low temperatures, drain or moisture could solidify or freeze, causing damage to the seals or equipment malfunction. Therefore, take appropriate measures to prevent freezing.

For compressed air quality, refer to the Air Preparation Equipment Selection Guide (**Web Catalogue**).

Operating Environment

Warning

1. Do not use in an atmosphere containing corrosive gases, chemicals, sea water, water, water steam, or where there is direct contact with any of these.
2. Do not expose the product to direct sunlight for an extended period of time.
3. Do not use in a place subject to heavy vibration and/or shock.
4. Do not mount the product in locations where it is exposed to radiant heat.
5. Products compliant with IP 65 satisfy the product specifications when mounted properly. Be sure to read the precautions for each product.

Operating Environment

Warning

6. If the product to be returned is contaminated or is possibly contaminated with substances that are harmful to humans, for safety reasons, please contact SMC beforehand and then employ a specialist cleaning company to decontaminate the product. After the decontamination prescribed above has been carried out, submit a Product Return Request Sheet or the Detoxification/Decontamination Certificate to SMC and await SMC's approval and further instructions before attempting to return the item.

Please refer to the International Chemical Safety Cards (ICSC) for a list of harmful substances.

If you have any further questions, please don't hesitate to contact your SMC sales representative.

Maintenance

Warning

1. Maintenance work

If handled improperly, compressed air can be dangerous. Maintenance of pneumatic systems should be performed by a knowledgeable and experienced person.

2. Removal of equipment, and supply/exhaust of compressed air

Before components are removed, first confirm that measures are in place to prevent workpieces from dropping, run-away equipment, etc. Then, cut off the supply pressure and electric power, and exhaust all compressed air from the system using the residual pressure release function.



EXA1 Series

Specific Product Precautions 1

Be sure to read this before handling the products. Refer to the back cover for safety instructions. For common precautions, refer to the “Operation Manual” on the SMC website: <https://www.smc.eu>

Design / Selection

Warning

1. Do not use beyond the specification range.

Using beyond the specification range may result in a fire, malfunction, or damage to the system.

Check the specifications before operation.

Caution

1. When applicable to UL, use a Class 2 power supply unit which is UL 1310 compliant for direct current power supply.

2. Use within the specified voltage range.

Using beyond the specified voltage range is likely to cause damage product or malfunction.

3. Do not remove the name plate.

Improper maintenance or incorrect use of the Operation Manual may lead to equipment failure or malfunction. Also, there is a risk of losing conformity with safety standards.

4. Beware of inrush currents when the power supply is turned on.

Some connected loads can apply an initial charge current which will trigger the over current protection function, causing the product to malfunction.

Mounting

Warning

1. When handling and assembling products:

- **Do not apply excessive force to the product when disassembling.**

The connecting parts of the product are firmly joined with seals.

- **When joining units, take care not to get your fingers caught between the products.**

Injury may result.

2. Do not drop, bump, or apply excessive impact to the product.

Doing so may result in damage, equipment failure, or malfunction.

Wiring

Caution

1. Provide grounding to improve noise immunity.

Perform the dedicated grounding separate from the inverter of the drive system and minimise the grounding distance from the product.

2. Avoid repeatedly bending or stretching the cable and applying heavy objects or force to it.

Wiring where repeated bending and tensile stress are applied to the cable may result in circuit breakage.

3. Avoid miswiring.

If miswired, there is a danger of malfunction or damage to the product.

4. Do not wire while energising the product.

There is a danger of malfunction or damage to the product or input/output device.

5. Avoid wiring the power line and high-voltage line in parallel.

Signal line noise or surge from the power line or high-pressure line could cause a malfunction.

Wiring of the product or input/output device and the power line or high-voltage line should be separated from each other.

6. Check the wiring insulation.

Defective insulation (contact with other circuits, improper insulation between terminals, etc.) may cause damage to the product or input/output device due to excessive voltage or current.

7. When the product is installed in machinery/equipment, provide adequate protection against noise by using noise filters, etc.

Noise in signal lines may cause a malfunction.

8. When connecting wires, prevent the entry of water, solvent, or oil from the connector section.

Failure to do so may result in damage, equipment failure, or malfunction.

9. Avoid wiring patterns in which excessive stress is applied to the connector.

Failure to do so may result in equipment failure or malfunction due to contact failure.



EXA1 Series

Specific Product Precautions 2

Be sure to read this before handling the products. Refer to the back cover for safety instructions. For common precautions, refer to the “Operation Manual” on the SMC website: <https://www.smc.eu>

Operating Environment

Warning

- 1. Do not use in atmospheres containing inflammable or explosive gases.**

Use in such atmospheres is likely to cause a fire or explosion.
This product is not explosion proof.

Caution

- 1. Provide adequate protection when operating in locations such as the following.**

Failure to do so may cause a malfunction or equipment failure.
The effect of countermeasures should be checked in individual equipment and machines.

- 1) Where noise is generated by static electricity, etc.
- 2) Where there is a strong electric field
- 3) Where there is a danger of exposure to radiation
- 4) When in close proximity to power lines or high-voltage lines

- 2. Do not use in environments where oil and chemicals are used.**

Operating in environments where coolants, cleaning solvents, various oils, or chemicals are present may cause adverse effects (damage, malfunction, etc.) to the product even within a short period of time.

- 3. Do not use in environments where the product could be exposed to corrosive gases or liquids.**

Use in such environments may cause product damage or malfunction.

- 4. Do not use in locations with sources of surge generation.**

Installation of the product in an area around equipment (electromagnetic lifters, high-frequency induction furnaces, welding machines, motors, etc.) which generates large surge voltages could cause an internal circuitry element of the product to deteriorate or result in damage. Implement countermeasures against the surge from the generating source, and avoid contact between the lines.

- 5. The product is CE marked but not immune to lightning strikes. Take measures against lightning strikes in your system.**

- 6. Keep dust, wire scraps, and other foreign matter from entering the product.**

Such materials may cause equipment failure or malfunction.

- 7. Do not use in places where there are cyclic temperature changes.**

When the cyclic temperature exceeds normal temperature changes, the internal product is likely to be adversely affected.

Adjustment / Operation

Warning

- 1. Do not perform operation or setting with wet hands.**

There is a risk of electrical shock.

Caution

- 1. Use a watchmaker's screwdriver with a thin blade for the setting switch.**

When setting the switch, do not touch any unrelated parts.
This may cause parts damage or malfunction due to a short circuit.

- 2. Perform appropriate setting for the operating conditions.**

Failure to do so could result in malfunction.
Refer to the Operation Manual for details on setting each switch.

- 3. For details on programming and address setting, refer to the manual from the PLC manufacturer.**

The programming content related to the protocol is designed by the manufacturer of the PLC used.



ITV2050 to 3050-X399

Specific Product Precautions

Be sure to read this before handling the products. Refer to the back cover for safety instructions. For common precautions, refer to the “Operation Manual” on the SMC website: <https://www.smc.eu>

Handling

Caution

1. If the power supply to this product is turned off due to a power failure during operation, the output on the secondary side depends on the specifications.

Normally closed specification:

The output pressure is held.

Normally open specification:

Supply pressure minus 0.1 MPa or more pressure continues to flow out.

2. If supply pressure to this product is interrupted or shut off, while the power is still on, the internal solenoid valve will continue to operate and a humming noise will be generated.
Since it may greatly affect the life of the built-in solenoid valve, when shutting off the supply pressure, turn off the power of this product or set the solenoid valve stop time.
3. This product is adjusted for each specification at the time of shipment from the factory. Avoid careless disassembly or removal of parts, as failure to do so may result in a malfunction.
4. When connecting the cable to this product, turn the lock ring of the cable. If a portion other than the lock ring of the cable is turned, it may damage the connector on the body. Turn the lock ring by hand without using a tool.
5. The right angle cable does not rotate and is limited to only one entry direction. If the right angle cable is rotated forcibly, the cable may be broken or damaged, or may damage the connector on the body.
6. Specifications on page 2 4 are in case of static environment. Pressure may fluctuate when air is consumed at the output side.



AR20S to 50S Series Specific Product Precautions 1

Be sure to read this before handling the products. Refer to the back cover for safety instructions. For common precautions, refer to the "Operation Manual" on the SMC website: <https://www.smc.eu>

Design / Selection

Warning

1. Provide ventilation when using this product in a confined area, such as in a closed control panel. For example, install a ventilation opening, etc., in order to prevent pressure from increasing inside of the confined area and to release the heat generated by this product.
2. Polyacetal resin parts are used for the exterior. Organic solvents including thinner, acetone, alcohol and ethylene chloride; chemicals including sulphuric acid, nitric acid and hydrochloric acid; cutting oil, synthetic oils, ester-based compressor oil, alkali, kerosene, gasoline, lock material of screw are harmful. Do not use the product where these are present.

Caution

1. Pay attention to the leakage voltage. Particularly when using a C-R element (surge voltage suppressor) to protect the switching element, take note that leakage current will flow through the C-R element, thus increasing leakage voltage.

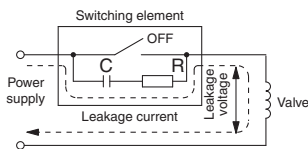

AC coil is 8 % or less of the rated voltage.
DC coil is 3 % or less of the rated voltage.

2. Use caution when operating at low temperatures. Although this product can be operated at temperature as low as 0 °C, measures should be taken to avoid solidifying or freezing drainage or moisture, etc.
3. Surge voltage suppressor

The surge voltage suppressor built into the valve is intended to protect the output contacts so that the surge generated inside valve does not adversely affect the output contacts. Therefore, if an overvoltage or overcurrent is received from an external peripheral device, the surge voltage protection element inside the valve is overloaded, causing the element to break. In the worst case, the breakage causes the electric circuit to enter short-circuit status. If energising continues while in this state, a large current flows. This may cause secondary damage to the output circuit, external peripheral device, or valve, and may also cause a fire. So, take appropriate protective measures, such as the installation of an overcurrent protection circuit in the power supply or a drive circuit to maintain a sufficient level of safety.

Adjustment

Warning

1. Set the regulator while verifying the displayed values of the inlet and outlet pressure gauges. Turning the regulator knob excessively can cause damage to the internal parts.
2. Do not use tools on the pressure regulator knob as this may cause damage. It must be operated manually.

Caution

1. When setting the pressure, the inlet pressure must be supplied after the pilot valve is powered.
2. Be sure to unlock the knob before adjusting the pressure and lock it after setting the pressure. Failure to follow this procedure can cause damage to the knob and the outlet pressure may fluctuate.
 - Pull the pressure regulator knob to unlock. (You can visually verify this with the "orange mark" that appears in the gap.)
 - Push the pressure regulator knob to lock. When the knob is not easily locked, turn it left and right a little and then push it (when the knob is locked, the "orange mark", i.e., the gap will disappear).

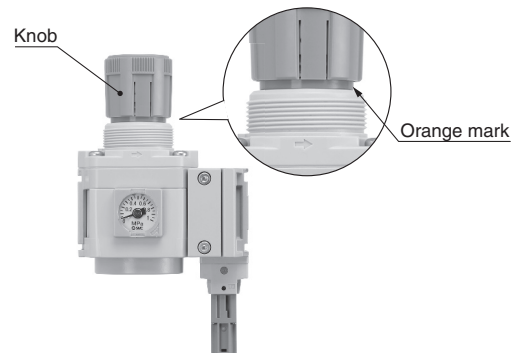



AR20S to 50S Series

Specific Product Precautions 2

Be sure to read this before handling the products. Refer to the back cover for safety instructions. For common precautions, refer to the “Operation Manual” on the SMC website: <https://www.smc.eu>

Wiring

Warning

1. The solenoid valve is an electrical product. For safety, install an appropriate fuse and circuit breaker before use.

Operating Environment

Warning

1. When the solenoid valve is mounted in a control panel or it's energised for a long period of time, make sure the ambient temperature is within the specifications of the valve.

Maintenance

Warning

1. Low-frequency operation

Valves should be operated at least once every 30 days to prevent malfunction. (Use caution regarding the air supply.)

2. Manual override

When a manual override is operated, connected equipment will be actuated. Operate only after safety is confirmed.

• Non-locking push type

Push down on the manual override with a small screwdriver, etc., until it stops. Release the screwdriver and the manual override will return.

• Push-turn locking lever type

When locking the manual override, be sure to push it down before turning. Do not apply excessive torque as turning without first pushing it down can cause damage to the manual override and trouble such as air leakage. (0.1 N·m)



VP346E/546E/746E/946E-X660/X661

Specific Product Precautions 1

Be sure to read this before handling the products. Refer to the back cover for safety instructions. For common precautions, refer to the "Operation Manual" on the SMC website: <https://www.smc.eu>

Design / Selection

Warning

1. Resumption after a long period of holding time

When resuming operation after a long period of holding time, there are cases in which, regardless of whether the product is in an ON or OFF state, there is a delay in the initial response time due to adhesion. Conducting several cycles of running-in operation will solve this problem. Please consider implementing this before resumption.

Caution

1. Surge voltage suppressor

1) The surge voltage suppressor built into the valve is intended to protect the output contacts so that the surge generated inside valve does not adversely affect the output contacts. Therefore, if an overvoltage or overcurrent is received from an external peripheral device, the surge voltage protection element inside the valve is overloaded, causing the element to break. In the worst case, the breakage causes the electric circuit to enter short-circuit status. If energising continues while in this state, a large current flows. This may cause secondary damage to the output circuit, external peripheral device, or valve, and may also cause a fire. So, take appropriate protective measures, such as the installation of an overcurrent protection circuit in the power supply or a drive circuit to maintain a sufficient level of safety.

2) If a surge protection circuit contains nonstandard diodes, such as Zener diodes or varistor, a residual voltage that is in proportion to the protective circuit and the rated voltage will remain. Therefore, take into consideration the surge voltage protection of the controller.

2. For the pilot EXH port (breathing hole)

If the valve pilot EXH port (breathing hole) is restricted extremely or blocked, abnormal operation of the valve may occur.

Piping

Caution

1. Silencer mounting

For handling of silencers, refer to the AN series/specific product precautions.

Handling

Warning

1. Built-in check valve

A check valve is built into the pilot flow path to suppress the pilot pressure drop due to pressure fluctuation on the inlet side. When replacing pilot valve, please be careful for residual pressure between check valve and pilot valve.

Adjustment

Caution

1. Soft start-up function

When the soft start-up function is selected, the initial pressure of the pneumatic system can be increased gradually.

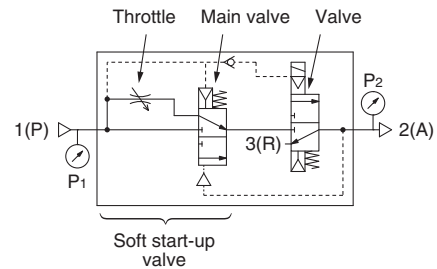

Output Pressure (P₂) vs Time Graph

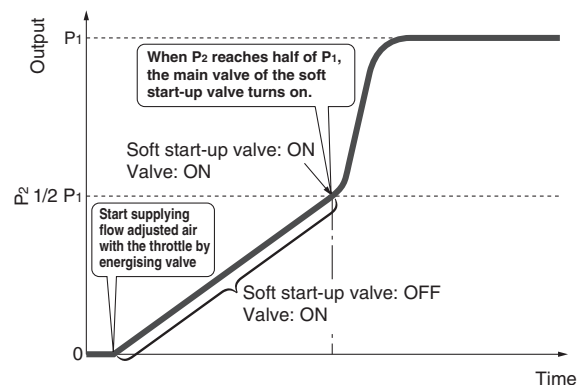

Turn the needle of the throttle valve to the left from fully closed (as shipped) to adjust the initial speed of the drive equipment on the outlet side.

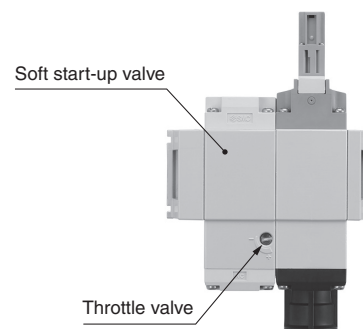



VP346E/546E/746E/946E-X660/X661

Specific Product Precautions 2

Be sure to read this before handling the products. Refer to the back cover for safety instructions. For common precautions, refer to the “Operation Manual” on the SMC website: <https://www.smc.eu>

Wiring

Warning

1. The solenoid valve is an electrical product. For safety, install an appropriate fuse and circuit breaker before use.

Operating Environment

Warning

1. When the solenoid valve is mounted in a control panel or it's energised for a long period of time, make sure the ambient temperature is within the specifications of the valve.

Maintenance

Warning

1. Low-frequency operation



Valves should be operated at least once every 30 days to prevent malfunction. (Use caution regarding the air supply.)

2. Manual override

When a manual override is operated, connected equipment will be actuated. Operate only after safety is confirmed.

Safety Instructions

These safety instructions are intended to prevent hazardous situations and/or equipment damage. These instructions indicate the level of potential hazard with the labels of “Caution,” “Warning” or “Danger.” They are all important notes for safety and must be followed in addition to International Standards (ISO/IEC)¹⁾, and other safety regulations.

-  **Caution:** **Caution** indicates a hazard with a low level of risk which, if not avoided, could result in minor or moderate injury.
-  **Warning:** **Warning** indicates a hazard with a medium level of risk which, if not avoided, could result in death or serious injury.
-  **Danger:** **Danger** indicates a hazard with a high level of risk which, if not avoided, will result in death or serious injury.

- 1) ISO 4414: Pneumatic fluid power – General rules relating to systems.
ISO 4413: Hydraulic fluid power – General rules relating to systems.
IEC 60204-1: Safety of machinery – Electrical equipment of machines.
(Part 1: General requirements)
- ISO 10218-1: Manipulating industrial robots - Safety.
etc.

Warning

1. The compatibility of the product is the responsibility of the person who designs the equipment or decides its specifications.

Since the product specified here is used under various operating conditions, its compatibility with specific equipment must be decided by the person who designs the equipment or decides its specifications based on necessary analysis and test results. The expected performance and safety assurance of the equipment will be the responsibility of the person who has determined its compatibility with the product. This person should also continuously review all specifications of the product referring to its latest catalogue information, with a view to giving due consideration to any possibility of equipment failure when configuring the equipment.

2. Only personnel with appropriate training should operate machinery and equipment.

The product specified here may become unsafe if handled incorrectly. The assembly, operation and maintenance of machines or equipment including our products must be performed by an operator who is appropriately trained and experienced.

3. Do not service or attempt to remove product and machinery/equipment until safety is confirmed.

1. The inspection and maintenance of machinery/equipment should only be performed after measures to prevent falling or runaway of the driven objects have been confirmed.
2. When the product is to be removed, confirm that the safety measures as mentioned above are implemented and the power from any appropriate source is cut, and read and understand the specific product precautions of all relevant products carefully.
3. Before machinery/equipment is restarted, take measures to prevent unexpected operation and malfunction.

4. Contact SMC beforehand and take special consideration of safety measures if the product is to be used in any of the following conditions.

1. Conditions and environments outside of the given specifications, or use outdoors or in a place exposed to direct sunlight.
2. Installation on equipment in conjunction with atomic energy, railways, air navigation, space, shipping, vehicles, military, medical treatment, combustion and recreation, or equipment in contact with food and beverages, emergency stop circuits, clutch and brake circuits in press applications, safety equipment or other applications unsuitable for the standard specifications described in the product catalogue.
3. An application which could have negative effects on people, property, or animals requiring special safety analysis.
4. Use in an interlock circuit, which requires the provision of double interlock for possible failure by using a mechanical protective function, and periodical checks to confirm proper operation.

Caution

1. The product is provided for use in manufacturing industries.

The product herein described is basically provided for peaceful use in manufacturing industries. If considering using the product in other industries, consult SMC beforehand and exchange specifications or a contract if necessary. If anything is unclear, contact your nearest sales branch.

Limited warranty and Disclaimer/Compliance Requirements

The product used is subject to the following “Limited warranty and Disclaimer” and “Compliance Requirements”. Read and accept them before using the product.

Limited warranty and Disclaimer

1. The warranty period of the product is 1 year in service or 1.5 years after the product is delivered, whichever is first.²⁾ Also, the product may have specified durability, running distance or replacement parts. Please consult your nearest sales branch.
2. For any failure or damage reported within the warranty period which is clearly our responsibility, a replacement product or necessary parts will be provided. This limited warranty applies only to our product independently, and not to any other damage incurred due to the failure of the product.
3. Prior to using SMC products, please read and understand the warranty terms and disclaimers noted in the specified catalogue for the particular products.
- 2) Vacuum pads are excluded from this 1 year warranty.
A vacuum pad is a consumable part, so it is warranted for a year after it is delivered. Also, even within the warranty period, the wear of a product due to the use of the vacuum pad or failure due to the deterioration of rubber material are not covered by the limited warranty.

Compliance Requirements

1. The use of SMC products with production equipment for the manufacture of weapons of mass destruction (WMD) or any other weapon is strictly prohibited.
2. The exports of SMC products or technology from one country to another are governed by the relevant security laws and regulations of the countries involved in the transaction. Prior to the shipment of a SMC product to another country, assure that all local rules governing that export are known and followed.

Caution

SMC products are not intended for use as instruments for legal metrology.

Measurement instruments that SMC manufactures or sells have not been qualified by type approval tests relevant to the metrology (measurement) laws of each country. Therefore, SMC products cannot be used for business or certification ordained by the metrology (measurement) laws of each country.

Safety Instructions

Be sure to read “Handling Precautions for SMC Products” (M-E03-3) before using.

SMC Corporation (Europe)

Austria	+43 (0)2262622800	www.smc.at	office@smc.at
Belgium	+32 (0)33551464	www.smc.be	info@smc.be
Bulgaria	+359 (0)2807670	www.smc.bg	office@smc.bg
Croatia	+385 (0)13707288	www.smc.hr	office@smc.hr
Czech Republic	+420 541424611	www.smc.cz	office@smc.cz
Denmark	+45 70252900	www.smc.dk.com	smc@smcdk.com
Estonia	+372 651 0370	www.smcee.ee	info@smcee.ee
Finland	+358 207513513	www.smc.fi	smc.fi@smc.fi
France	+33 (0)164761000	www.smc-france.fr	supportclient@smc-france.fr
Germany	+49 (0)61034020	www.smc.de	info@smc.de
Greece	+30 210 2717265	www.smchellas.gr	sales@smchellas.gr
Hungary	+36 23513000	www.smc.hu	office@smc.hu
Ireland	+353 (0)14039000	www.smcautomation.ie	sales@smcautomation.ie
Italy	+39 03990691	www.smcitalia.it	mailbox@smcitalia.it
Latvia	+371 67817700	www.smc.lv	info@smc.lv

Lithuania	+370 5 2308118	www.smclt.lt	info@smclt.lt
Netherlands	+31 (0)205318888	www.smc.nl	info@smc.nl
Norway	+47 67129020	www.smc-norge.no	post@smc-norge.no
Poland	+48 222119600	www.smc.pl	office@smc.pl
Portugal	+351 214724500	www.smc.eu	apoioclientept@smc.smces.es
Romania	+40 213205111	www.smcromania.ro	smcromania@smcromania.ro
Russia	+7 (812)3036600	www.smc.eu	sales@smcru.com
Slovakia	+421 (0)413213212	www.smc.sk	office@smc.sk
Slovenia	+386 (0)73885412	www.smc.si	office@smc.si
Spain	+34 945184100	www.smc.eu	post@smc.smces.es
Sweden	+46 (0)86031240	www.smc.nu	smc@smc.nu
Switzerland	+41 (0)523963131	www.smc.ch	info@smc.ch
Turkey	+90 212 489 0 440	www.smcturkey.com.tr	satis@smcturkey.com.tr
UK	+44 (0)845 121 5122	www.smc.uk	sales@smc.uk

South Africa +27 10 900 1233 www.smcza.co.za zasales@smcza.co.za